

**SAWBLADES**

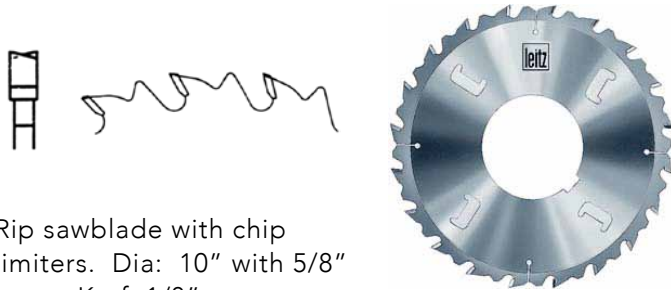

LEITZ SAWBLADES from GERMANY offer high-tech engineering. Blades have fine-grain industrial carbide tips. Pre-tensioned steel plates keep the blade running steady and true. Copper plugs in the body of the blade help reduce vibration. State-of-the-art Leitz design features add up to superior cuts and a longer-life sawblade!

**LEITZ RIP SAWBLADE**



Rip sawblade with chip limiters. Dia: 10" with 5/8" bore. Kerf: 1/8"

Code	Teeth	Grind	List/ea
831R-ATB	24T	ATP pos.	\$ 120.45

**LEITZ RIP & CROSSCUT SAWBLADE**



Rip and Crosscut Sawblade. Dia: 10" with 5/8" bore. Kerf: 1/8"

Code	Teeth	Grind	List/ea
790R-ATB	40T	ATB pos.	\$ 132.44

**LEITZ SAWBLADE**

For Cross-Cut and Man-Made Material

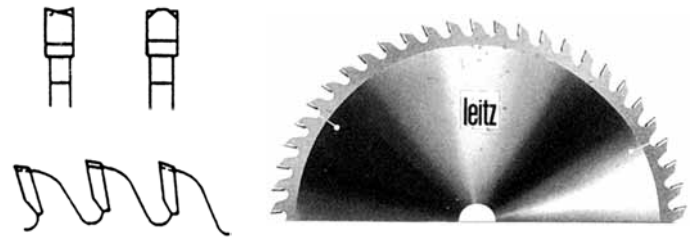

Dia: 10" with 5/8" Bore. Kerf: 1/8"

**For Cross-Cut:**

Code	Teeth	Grind	List/ea
792R-ATB	60T	ATB pos.	\$ 116.91

**For Man-Made Material:**

792R-TCG	60T	TC pos.	\$ 150.15
----------	-----	---------	-----------

**LEITZ FINE CUT SAWBLADE**

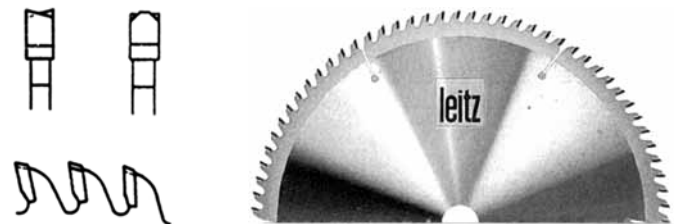

Dia: 10" with 5/8" Bore. Kerf: 1/8"

**For Fine Cross-Cut:**

Code	Teeth	Grind	List/ea
791R-ATB	80T	ATB pos.	\$ 145.58

**Man-Made Material (Fine Cut or Thin Material):**

791R-TCG	80T	TC pos.	\$ 168.19
----------	-----	---------	-----------



**SAWBLADES**

**LEITZ DOUBLE-SIDED LAMINATE BLADE**

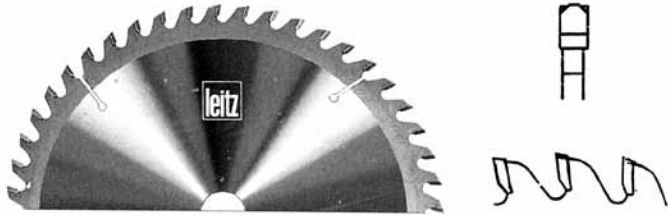

Sawblade for double-sided laminates, negative rake.  
Dia: 10" with 5/8" bore. Kerf: 1/8"

Code	Teeth	Grind	List/ea
843R-TCGN	60T	TC neg.	\$ 133.45

**LEITZ MELAMINE SAW BLADE**

Long-wearing tooth pattern: adjustable height for chip-free cutting.

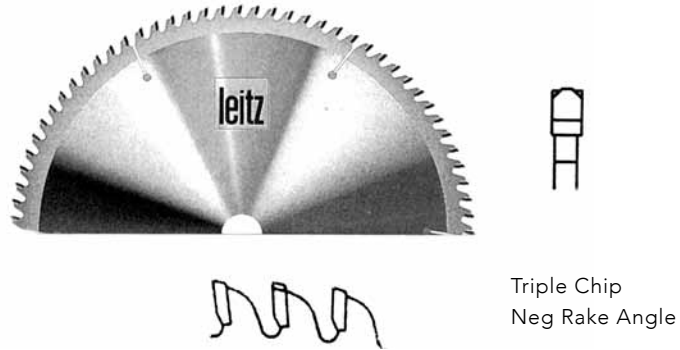

Triple Chip  
Neg Rake Angle

Sawblade for fine or thin cuts on double-sided laminates. Dia: 10" with 5/8" bore. Kerf: 1/8"

Code	Teeth	Grind	List/ea
844R-TCGN	80T	TC neg.	\$ 143.00

Triple chip design is said to stay sharp longer than ATB design in abrasive man-made panels; melamine, MDF, etc.



**LEITZ SAWBLADE FOR MITER OR RADIAL ARM SAWS**

For Fine Cuts

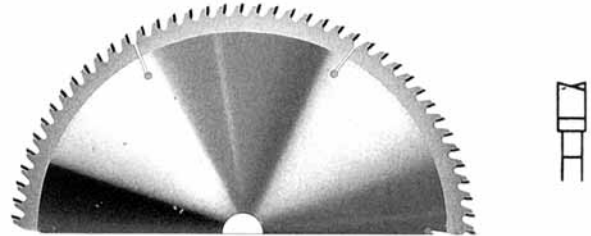

Sawblade fits on miter or radial arm saws. For fine cuts. Dia: 10" with 5/8" bore. Kerf: 1/8"

Code	Teeth	Grind	List/ea
838R-ATBN	80T	ATB neg.	\$ 169.85

**LEITZ MELAMINE SAWBLADE**

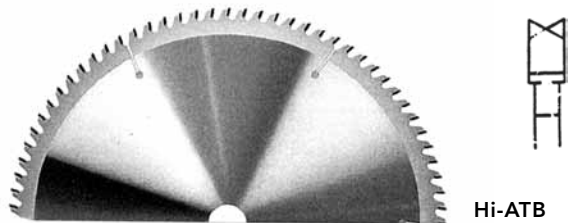

Hi-ATB  
Melamine Blade  
30° ATB  
Neg Rake Angle

This Hi-ATB Melamine Blade has a negative rake which makes it ideal for smooth, chip-free cuts in laminates. Adjust blade height to find best result. Dia: 10" with 5/8" bore. Kerf: 3.2mm

Code	Teeth	Grind	List/ea
838R-ATBN30	80T	ATBN 30°	\$ 145.14



CMT blades are made in Italy. All blades include patented carrying case and baked-on PTFE non-stick orange coating.

**SAWBLADES**

**CMT CUT-OFF ATB SAWBLADES**

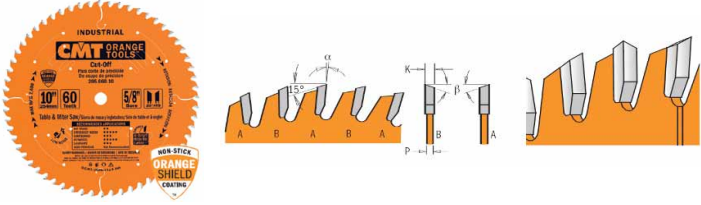

All-around cut off blade for hardwood, softwood, plywood and chip board. Alternate top bevel teeth, micrograin carbide 5° hook angle. 60 tooth. For use on table and miter saws.

- Bore Dia: 5/8", Blade Dia.: 10"
- Kerf Thickness: .102
- Plate Thickness: .079

Code	Description	List/ea
205.060.10	10" Dia, 60T	\$ 94.18

**CMT PRECISION DADO SET**

Set includes:

2 blades, 6 carbide tipped four tooth chippers and a set of 10 steel shims.

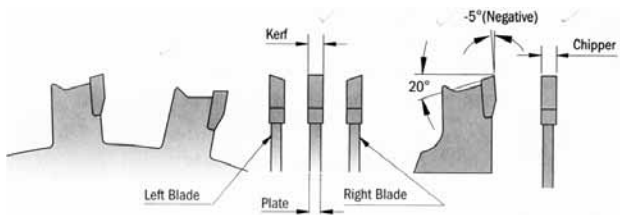

- Anti-kickback design
- Splinter resistant cuts in veneer plywood, melamine and hard and soft woods; chipper made especially for undersize plywood
- Six chipper blades. Four tooth design keep the cut flat and virtually free from tear out. Chipper sizes: 4 x 1/8", 1 x 3/32", 1 x 1/16"
- Shim sets included to set up any cut you want between 1/4" and 29/32"
- Micrograin carbide teeth
- Laser cut, high grade German steel blade body
- 5/8" Bore Dia.

Code	Description	List/ea
230.524.08	8" Dia, 24T	\$ 313.86

**CMT FINE CUT-OFF SAWBLADE**

High ATB for Melamine

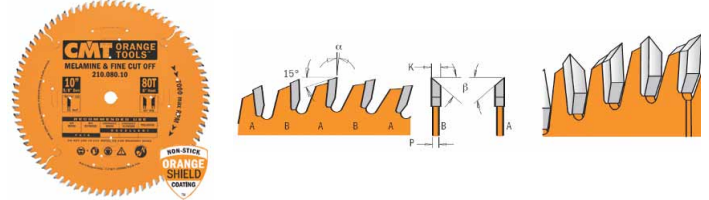

40° top bevel provides flawless finishing on melamine, hard and soft woods. Absolutely minimal chipping on double face material!

- 40° Bevel Angle, ATB
- Noise reducing laser cut channels
- Micrograin carbide teeth
- ATB grind, Hook Angle: 5°
- Kerf thickness: .126, Plate Thickness: .087

Code	Description	List/ea
210.080.10	10" Dia, 80T	\$ 130.42

**CMT COMPOUND MITER & RADIAL SAW**

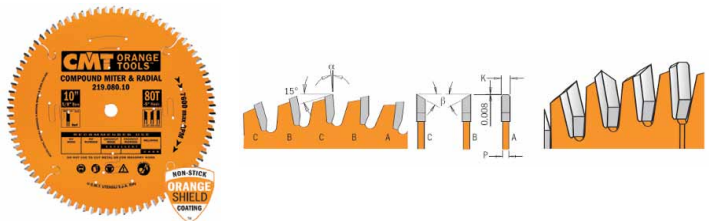

- The -5° hook angle, thin kerf, 30° bevel, and high tooth count allow smooth cuts in plywood, solid wood and laminates. Micrograin carbide tips.
- The negative hook angle keeps blade from climbing at aggressive feed rates.
- Noise-reducing laser cut channels
- Grind: 4ATB+1FTG raker
- Hook Angle: -5°, Kerf: 0.114, Plate Thickness: .098

Code	Description	Bore	List/ea
219.060.08	8-1/2" Dia, 60T	5/8"	\$ 95.69
219.080.10	10" Dia, 80T	5/8"	122.98
219.090.12	12" Dia, 90T	1"	167.18



SAWBLADES

CNC TOOLING

LEUCO SAWBLADES - Special Order



HG: Hollow ground  
Pos: Positive Hook  
Neg: Negative Hook

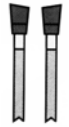

ATB -  
Alternate  
top bevel



TCG -  
Triple chip  
grind



HG -  
Hollow  
Grind

Table Saw Blades

Code	Dia.	Bore	Teeth	Saw	Net/ea
188426	10"	5/8"	50T ATB Flat	Chip	\$ 80.19
80231459	10"	5/8"	60T ATB	Table	102.00
188435	10"	5/8"	60T TCG	Table	81.35
188418	10"	5/8"	80T ATB	Table	86.02
188436	10"	5/8"	80T TCG	Table	90.22
188432	10"	5/8"	24T TCG	Rip	59.83

Melamine Saws

			Hook	
181995	250mm x 30mm	80T High-ATB	-2°	\$ 81.67
181996	300mm x 30mm	96T High-ATB	2°	95.42

Altendorf Sliders/Striebig Vertical Panel Saws

(use similar sizers)

188979	300mm x 30mm	72T TCG	10°	\$ 107
188661	300mm x 30mm	96T ATB	10°	98
188980	300mm x 30mm	96T TCG	10°	114
169739	300mm x 30mm	60T HG	-6°	109
		Neg. Hook		
169738	300mm x 30mm	60T HG	10°	110
		Pos. Hook		

Split Scoring Blades

169892	100mm x 22mm	2x10 Alten, Martin, Strei	\$ 104
169883	120mm x 22mm	2x12 Alten, Martin	109
188528	120mm x 20mm	2x12 SCM	112
188398	120mm x 50mm	2x12 Altendorf	124
		Rapido Split Scoring	

Holz Her

169737	220mm x 30mm	42T HG Pos.	\$ 87
181716	220mm x 30mm	64T TCG	110

LEUCO: CNC TOOLING - Special Order

Spiral Router Bits - Solid Carbide



2 Flute Down Cut Spiral Bits

Designed for solid woods, wood composites and some plastics. This bit is used where a downward chip removal is required. Provides downward pressure and leaves an excellent finish on the top.

Code	Cutting			Overall Length	Net
	Outside Dia.	Edge Length	Shank		
500009	1/4"	1"	1/4"	2-1/2"	\$ 17
1721018	3/8"	1-1/4"	3/8"	3"	33
1720573	1/2"	1-1/4"	1/2"	3-1/2"	55
500021	1/2"	1-5/8"	1/2"	3-1/2"	65

2 Flute Up Cut Spiral Bits

Designed for solid woods, wood composites and some plastics. This bit is used where an upward chip removal is required. Provides upward pressure. Chip removal is optimized but adequate hold down is needed.

Code	Cutting			Overall Length	Net
	Outside Dia.	Edge Length	Shank		
500008	1/4"	1"	1/4"	2-1/2"	\$ 18
1721019	3/8"	1-1/4"	3/8"	3"	33
1720572	1/2"	1-1/4"	1/2"	3-1/2"	55
500020	1/2"	1-5/8"	1/2"	3-1/2"	55

2 Flute Compression Spiral Bits (2 + 2)

Designed for double-sided laminated or veneered materials. This bit is used where an excellent finish for both top and bottom is required.

Code	Cutting			Overall Length	Net
	Outside Dia.	Edge Length	Shank		
1721351	1/4"	1"	1/4"	2-1/2"	\$ 56
1731181	3/8"	1-1/4"	3/8"	3"	75
1727268	1/2"	1-1/4"	1/2"	3"	88
500059	1/2"	1-5/8"	1/2"	3-1/2"	92
1720542	1/2"	2-1/8"	1/2"	4"	96

**DRILL BITS**

**CMT SPIRAL BITS - 2 Flute**

Solid Carbide



191  
Upcut Spiral

Code	Shank	Cut Dia.	Cut Length	Ovall Length	List
191.008.11	1/4"	1/4"	1"	2-1/2"	\$ 26.18
191.505.11	1/2"	1/2"	1-1/4"	3"	82.36
191.507.11	1/2"	1/2"	2"	4"	98.43

**FULLER STANDARD TWIST DRILLS**



High-quality, U.S. made, high speed steel twist drills; for drilling wood, plastic, and metal.

Code	Size	Flute Length	Overall Length	List/ea
151-116	1/16"	7/8"	1-7/8"	\$ 2.49
151-564	5/64"	1"	2"	2.47
151-332	3/32"	1-1/4"	2-1/4"	2.86
151-764	7/64"	1-1/2"	2-5/8"	2.64
151-18	1/8"	1-5/8"	2-3/4"	3.19
151-964	9/64"	1-3/4"	2-7/8"	3.05
151-532	5/32"	2"	3-1/8"	3.15
151-1164	11/64"	2-1/8"	3-1/4"	3.23
151-316	3/16"	2-5/16"	3-1/2"	5.25
151-732	7/32"	2-1/2"	3-3/4"	4.94
151-14	1/4"	2-3/4"	4"	4.68
151-516	5/16"	3-3/16"	4-1/2"	7.93
151-38	3/8"	3-5/8"	5"	10.76
151-12	1/2"	1/2"	6"	19.33
151-1564	15/64"	2-5/8"	3-7/8"	5.66

(For use with undermount drilling jigs (V6JIG))

**AMANA BRAD POINT BORING BIT**

Positive ground spurs for rapid easy boring into hardwoods. Ideal for hinge boring machines and line boring machines that may have limited power, or bore mostly hardwood.

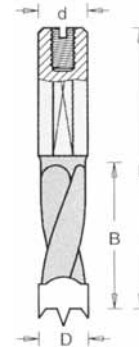

L = 57 mm long,  
(d) 10 mm x  
(B) 27 mm shank

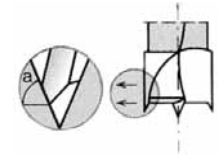

RH	LH	D	List/ea
201005	301005	5 mm	\$ 19.86
201008	301008	8 mm	30.09
-----	301010	10 mm	32.46

**METRIC BRAD POINT DRILLS**



5mm or 10mm

Excellent quality High Speed Steel woodworking bit. Designed for standard 3-jaw chucks. Carded, 1 ea/cd.

Code	Dia.	Overall Length	List/cd
570-7050	5mm	90mm (3-1/2")	\$ 20.98
570-7100	10mm	130mm (5")	27.27

**FULLER BRAD POINT DRILLS**



High Speed Steel brad point drill for clean holes in wood, plastic and sheet metal.

Code	Dia.	Overall Length	List/ea
281-5MM	5mm	3-5/8"	\$ 11.63
251-316	3/16"	3-1/2"	9.58





**DRILL BITS**

**BOSCH CARBIDE TIPPED BORING BITS**

Industrial Carbide Tipped.  
Shank Size: 10mm x 20mm.

Overall Length: 57mm. With adjustable top screw.



Code	Hand	Dia.	List/ea
T15035	RH	35mm	\$ 44.97
T15040	RH	40mm	47.77

**BOSCH TWIST HINGE BORING BIT**



Shank: 10 x 26mm with adjustable top screw

Boring bits for multi-spindlemachines. Use on most automatic & semi-automatic boring machines. Fits almost any European boring machines.

Max. Boring Depth: 36mm. Shank: 10 x 26mm.  
Overall Length: 57mm. With adjustable top screw.  
Positive grind for hardwoods.

Code	Hand	Dia.	List/ea
T15015	LH	5mm	\$ 19.51
T15005	RH	5mm	20.59
T15018	LH	8mm	25.41
T15008	RH	8mm	25.42

**CMT CARBIDE TIPPED BORING BITS**

"Fatigue proof" Swiss steel body, micrograin carbide tips, bake-on non-stick coating and honed edges. Made in Italy. Negative ground spurs on boring bits give clean cuts in melamine without chipping.

**2 FLUTE DOWEL DRILL**

CMT



Size	RH	LH	Length	List
5mm	310.050.11	310.050.12	57.5mm	\$ 14.52
8mm	310.080.11	310.080.12	57.5mm	20.91
5mm	311.050.11	311.050.12	70mm	19.77
8mm	311.080.11	311.080.12	70mm	18.70

**2 FLUTE DOWEL DRILL FOR THROUGH HOLES**

CMT

Overall Length: 70mm



Size	RH	LH	List
5mm	314.050.11	314.050.12	\$ 26.22
7mm	314.070.11	314.070.12	28.50

**HINGE BORING BIT**

CMT

Overall Length: 57.5mm



Size	RH	List
26mm	317.260.11	\$ 46.99
35mm	317.350.11	38.32
40mm	317.400.11	63.55

**CMT FORSTNER BIT WITH PARALLEL SHANK**

Overall Length: 90mm,  
High Speed Steel.  
Right Hand.  
For drill press.



Size	RH	List
35mm	537.350.31	\$ 21.52

**COUNTERBORES**

**FACE FRAME COUNTERBORE**

Amana



Precision ground carbide-tipped counterbore for splinter-free cutting. Non-slip surface treatment for positive clamping. Wide web design for superior strength and replaceable HSS fishtail drills. Will fit Ritter faceframe machines.

Code	Dia	Shank	OA Length	List/ea
424000	3/8"	3/8"	4-1/2"	\$ 44.40

**REPLACEMENT BIT FOR COUNTERBORES**



High speed steel replacement bit for above face frame counterbores. #29 fishtail point. 2-7/8" Overall Length. Sold per each.

Code	Dia	OA Length	List/ea
424004	.136	2-7/8"	\$ 10.51

**STEP DRILL FOR CONNECTING SCREWS**

Quickscrews



Overall Length: 5-3/4"

Drills 3 different diameters in one operation: 5mm, 7mm, 10mm.

Code	Description	List/ea
12793	High Speed Steel	\$ 43.85

**FULLER HEX SHANK DRILLS**

Taper Point



1/4" Hex Drive Shank

Hex shank fits Deerwood bit holder and Insty-bit quick-change bit holder. Change from screwdriver bits to drill bits and back with ease.

Code	Drill Dia.	Wood Screw Size	Flute Length	Overall Length	List/ea
40125	1/8"	5	1-5/8"	3-1/2"	\$ 9.86
40140	9/64"	6	1-3/4"	3-5/8"	10.54
20140171	11/64"	8	2-1/8"	3-15/16"	12.26
40203	13/64"	10	2-7/16"	4-3/8"	13.30

**CMT FORMULA 2050 - BLADE AND BIT CLEANER**

A safe, environmentally-friendly cleaner that is more effective than the various hazardous chemicals used to clean cutting tools.

Non-toxic, non-flammable and certified biodegradable, it penetrates the microscopic cracks in the resin and attacks the bond between it and the carbide or steel surfaces. The resin releases its grip and you simply wipe it off.



18 oz. spray bottle    1 Gal Jug

Keeps tools clean and helps increase the life span between sharpenings and replacement. Use on all wood-working cutting tools: i.e. sawblades, router bits, drill bits, shaper cutters, planer blades, etc.

Code	Description	Ctn	List/ea
998.001.01	18 oz. spray bottle	12 ea.	\$ 14.20
998.001.03	1 gallon jug	4 ea.	49.65



## FULLER COUNTERSINKS

### FULLER TYPE "C" COUNTERSINKS

With 82° Angle

To cut woods and plastics for heads of wood screws. Drills, counter-sinks and counter-bores in one quick operation. Makes driving screws easier and assures the best possible holding power. Designed for clean cutting and hardened for long wear. Countersink to right shown mounted on a Taper Point Drill with a Stop Collar. The Countersinks can also be mounted on ordinary straight twist drills allowing the screw thread to cut its own hole or by using correct pilot drill size for root diameter of thread allowing shank of screw to force its way into the wood.

The countersink is held in place with two hex-socket screws and is easily adjustable up and down so **ONLY ONE COUNTERSINK AND ONE LENGTH OF DRILL IS REQUIRED FOR ANY LENGTH OF WOOD SCREW.**

Overall length of countersink: 7/8". Stop Collar can be furnished to control depth of cut. To cut wood plug to fit in hole over head of screw, use matching Plug Cutter.

### FULLER TAPER POINT DRILLS

High Speed Steel



To cut wood and plastics in one operation for the thread and shank of wood screws. Hold their sharp cutting edges longer. Recommended for most jobs whether in a drill press or in hand-held equipment. They cut well in both hard and soft wood.

Code	Screw Size	Cutting Dia.	Overall Length	List/ea
TD-5	#5	1/8"	2-3/4"	\$ 8.44
TD-6	#6	9/64"	2-7/8"	10.42
TD-7	#7	5/32"	3-1/8"	7.51
TD-8	#8	11/64"	3-1/4"	8.45
TD-9	#9	3/16"	3-1/2"	8.85
TD-10	#10	13/64"	3-5/8"	9.15
TD-12	#12	7/32"	3-3/4"	9.78
TD-SET	Set of 7 includes 1/8", 9/64", 5/32", 11/64", 3/16", 13/64" and 7/32"			58.29

### FULLER TYPE "C" COUNTERSINKS



Code	Cutting Dia.	Drill Hole Size	Screw Size	List/ea
CS5	3/8"	1/8"	#5	\$ 10.22
CS6	3/8"	9/64"	#6	9.66
CS7	3/8"	5/32"	#7	10.36
CS8	3/8"	11/64"	#8	9.66
CS9	3/8"	3/16"	#9	11.14
CS10	7/16"	13/64"	#10	11.41
CS12	1/2"	7/32"	#12	11.44

### FULLER STOP COLLARS



Designed to be used with Fuller Countersinks and Counterbores. These steel collars are held solidly in place with two set screws, to control depth of counterbores. The inside diameter of the stop collar fits the outside diameter of the Countersink or Counterbore.

Code	Size	List/ea
SC38	3/8" Ins. Diameter	\$ 4.25
SC-SET	Set of 7 includes 1/4", 5/16", 3/8", 7/16", 1/2", 9/16", 5/8"	29.88

Taper Point Drill shown here with Countersink and Stop Collar



--- Countersink  
--- Stop Collar

--- Taper Point Drill





## COUNTERSINKS

### AMANA COUNTERSINKS - CARBIDE TIPPED

2-Wing for Wood Screws  
Maximum 3/8" depth of cut

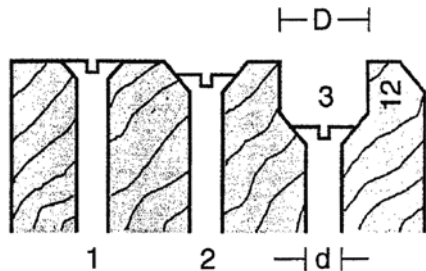

Tool No.	Suggested Wood Screw Size	Accepts *Drill Dia.	'D' Countersink Dia.	List
55202	#4	1/8	3/8	\$ 33.77
55204	#6	9/64	3/8	33.67
55208	#8-#9	11/64	13/32	36.60
55210	#10	3/16	13/32	37.46

Replacement set screws  
(2 required) No. 67092.  
Drills not included.

**Note:** 5/16" shank on tools 55200 through 55210.



## HOLE SAWS



### LENOX VARIABLE PITCH HOLE SAWS



To cut wood, plastic and metal. The variable pitch can reduce labor and costs, and its faster cutting and longer life outlasts 6 pitch saws in most applications. High speed steel M3 cutting edge with varying tooth sets and gullet depths. 4-6 teeth per inch.

Code	Size	List/ea
HS134	1-3/4"	\$ 21.58
HS2	2"	20.93
HS218	2-1/8"	25.87
HS21116	2-11/16"	26.49
HS238	2-3/8"	25.90
HS214	2-1/4"	24.31
HS212	2-1/2"	27.20
HS234	2-3/4"	27.36
HS418	4-1/8"	38.64

### HOLE SAW ARBORS AND PILOT DRILLS

High Speed Steel



58-09  
3/8" Hex Shank



58-08  
3/8" Hex Shank  
w/2 pins

Code	Fits Sizes:	List/ea
58-09	9/16" thru 1-3/16"	\$ 19.96
58-08	1-1/4" thru 6"	34.45

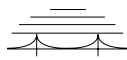

**BITS**

**MAGNETIC POWER BITS**

Quickscrews



6" Power Bit. Available in Phillips or Square Drive. Fits standard bit holder. Can be used with the TSM10 Castle Pocket Boring Machine. Drive face frame screws easily at low angles.

Pack: 10 ea.

Code	Description	List/ea
12694	6" Phillips Drive #2	\$ 5.98
12698	6" Square Drive #2	5.74

**COMBO HEAD SCREWDRIVER BIT**

Square/Phillip Drive combo Head



The 2X2QB combo head screwdriver bit has both Square drive and Phillips drive "teeth." This makes it a fine bit to use with the Quadrex white screws as well as the Spax screws. It fills both the Square drive and Phillip's recess of a Spax screw for max. driving power.

Code	Description	List
2X2QB	Combo Head Bit	\$ 5.40

**10-PIECE INSERT BIT KIT**

Quickscrews



Includes:

- #1 Phillips Drive Bit
- #2 Phillips Drive Bit
- #3 Phillips Drive Bit
- #2 Reduced Phillips Drive Bit
- #1 Pozi Drive Bit
- #2 Pozi Drive Bit
- #3 Pozi Drive Bit
- #1 Square Drive Bit
- #2 Square Drive Bit
- Quick Release Magnetic Bit Holder # 11922



Kit contains 9 bits, magnetic quick release bit holder (1/4" x 2") and case.

Code	Description	List/kit
13613	10 piece Bit Kit w/ case	\$ 18.87

**BIT HOLDERS**

**MAGNETIC BIT HOLDER**



11794 or M490

Use With 1/4" Hex Insert Bit. Body Dia: 1/4"

Code	Manufacturer	Overall Length	Pack	List/ea
11794	Quickscrews	2-7/8"	1 ea.	\$ 15.41
M490	Apex	3"	1	20.10



**QUICK RELEASE**

**MAGNETIC BIT HOLDER**

Quickscrews



14203

Stainless Steel Magnetic Bit Holder use with any type insert bit works in any standard drill chuck - Quick Release & Super Magnetic. 1/4" x 3".

Code	Description	List/ea
14203	Quick Release Bit Holder	\$ 11.74

**SUPER MAGNETIC BIT HOLDER**

Quickscrews



11928

1/4" Hex Shank, Overall Length: 2-3/8". Depth adjustable; locks for uniform driving depth.

- Can't Loose bit
- Holds Screw Straight
- Short Length for narrow space
- Adjustable depth stop

Code	Description	List/ea
11928	Super Mag Bit Holder	\$ 14.77

**SCREWDRIVER BITS**

- X - Prefix for extra hardness bits to be used for driving sheet metal or case hardened screws.
- I - Prefix for intermediate hardness bits to be used for driving heat-treated screws and for impact use.



1" Standard Length



Long Length

**FOR PHILLIPS SCREWS - 1/4" Hex Insert**  
440 Series

Code	Pt. Size	O.A. Length	List/ea
I440-1	1	1"	\$ 1.14
X440-1	1	1"	1.17
I440-2	2	1"	1.22
X440-2	2	1"	1.17
I440-3	3	1"	1.22
X440-3	3	1"	1.13
I440-22	2	2"	2.27
X440-22	2	2"	2.79
X440-23	2	3"	6.09
X440-215	2	1-1/2"	1.36

**FOR POZI DRIVE SCREWS**

1/4" Hex Insert  
440 Series



X440-2-PZD	2	1"	\$ 1.34
X440-3-PZD	3	1"	2.14

**FOR PHILLIPS SCREWS**

1/4" Hex Shank  
446 Series



I446-2	2	1"	\$ 1.23
X446-1	1	1"	1.30
X446-2	2	1"	1.18
11760 (QuickScrews)	2	1"	.87

**FOR PHILLIPS SCREWS**

5/16" Hex Shank  
480 Series



I480-2	2	1-1/4"	3.31
X480-2	2	1-1/4"	2.03

**SQUARE DRIVE BITS**



X950  
1/4" Hex Insert



X954  
1/4" Hex Power Drive

Code	Description	Ctn	List/ea
X950-1	1" Square Dr, #1	10	\$ 4.74
X950-2	1" Square Dr, #2	10	1.49
X954-2	1-15/16" Square Dr, #2	10	2.32
X954-B-2	3-1/2" Square Dr, #2	10	3.54

**FOR PHILLIPS SCREWS**

1/4" Hex Power Drive  
492 Series



Code	Pt. Size	O.A. Length	List/ea
X492	2	1-15/16"	\$ 1.89
X492-B	2	3-1/2"	2.78

**MAGNETIC POWER BITS**

Quickscrews



6" Power Bit. Available in Phillips or Square Drive.

Pack: 10 ea.

Code	Description	List/ea
12694	6" Phillips Drive #2	\$ 5.98
12698	6" Square Drive #2	5.74

**Note:**

When a #2 bit is needed we recommend the #2 446 Apex series for #5, #6 and short to medium #8 screws (this bit is also known as a #2 recess bit). The 446 series is commonly used to mount drawer slides, face frame plates, and Amerock style hinges.

The #2 440 Apex series is recommended for driving #8 and #10 screws (the 440 will fit smaller screws too, it just performs best on larger screw heads).

**VIX BITS**

**VIX BITS**



For speedy accurate drilling. Vix Bit is self-centering. It saves hours of time in accurately drilling holes for hinges, door butts, window pulls, door latch bolts & all hardware using screws. Precision built, it drills wood, metal, plastics, etc. Hardened drill guide. Adjustable for depth. Fully guaranteed.

<u>Code</u>	<u>Description</u>	<u>Ctn</u>	<u>List/ea</u>
5VI	7/64", Hex Drive	10 ea.	\$ 14.67
9VI	9/64", Hex Drive	10	15.45
12VI	11/64"	10	49.40
5MM-VI	5mm	10	40.04
14VI	1/4"	1	47.24

**Replacement Bits**

<u>Code</u>	<u>Size</u>	<u>Ctn</u>	<u>List/ea</u>
DRILL BIT-5	7/64"	10 ea.	\$ 3.32
DRILL BIT-9	9/64"	10	3.51
DRILL BIT-12	11/64"	10	6.62
DRILL BIT-5MM	5mm	10	7.22

**SELF-CENTERING HINGE BIT**

Adjustable Clamp



E-Z Mark™ Self-Centering Hinge Bits allow precise, centered drilling of fastener holes for hinge installation. During drilling, the spring loaded outer guide accurately centers the drill, while the steel guide sleeve retracts into its housing to ensure correct drilling depth.

All steel construction and high speed center drill provide consistent results in drilling wood, steel and plastics alike. These bits fit most electric and cordless drills and will unscrew easily for depth adjustment and cleaning.

<u>Code</u>	<u>Drill size</u>	<u>For Screw Size</u>	<u>Maximum Hole Depth</u>	<u>List/ea</u>
8912	11/64"	#12	11/16"	23.99

**FULLER STANDARD PLUG CUTTERS**



Designed for clean cutting and hardened for long life. These four-bladed Plug Cutters do not eject the plugs. The plug remains in the board and can be broken out with a screwdriver, or the board can be sawed to free the plug. The tool cuts fast and makes a smooth-chamfered plug for easy starting in the counterbored hole.

<u>Code</u>	<u>Plug Dia.</u>	<u>Max. Length</u>	<u>Shank Dia.</u>	<u>List/ea</u>
PC38	3/8"	1/2"	3/8"	\$ 19.56
PC716	7/16"	1/2"	3/8"	21.10
PC12	1/2"	1/2"	3/8"	22.76
PC-SET	Set of all three on a Labeled Block			\$ 64.77

**DRILL JIGS**

**DRILL GUIDE FOR LINE BORING**

Align-Rite



For line-boring with a hand held drill. Has adjustable stops for custom-drilling; the end stop is preset 8mm to center of first hole; the side stops are preset for a 37mm set back from the front edge. Available with either 5mm (32mm C to C) or 1/4"(1-1/4 C to C) replaceable hardened bushings and corresponding drill stop. Guide is made of anodized aluminum and bushings are hardened steel.

<u>Code</u>	<u>Description</u>	<u>List/ea</u>
DG-102	1/4" Drill Bushings, 1-1/4" C/C	\$ 238.89
DG-103	5mm Drill Bushings, 32mm C/C	167.03
570-7050	5mm Drill Bit for 3-jaw chuck	20.98

**DRILL GUIDE FOR DOORS & DRAWERS**

Align-Rite

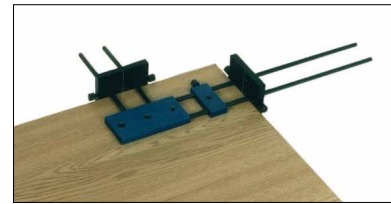

Machined with precision for accurate alignment of handles and knobs. The guide line on the fence assures fast and accurate centering. Handles and knobs can be centered on drawers up to 12" high. The drill guide adjusts easily from drawers to doors. Made of anodized aluminum with replaceable hardened steel bushings. Has adjustable hole centers for handles. Uses a standard 3/16" drill bit.

<u>Code</u>	<u>Description</u>	<u>List/ea</u>
DG-101	Drill Guide for Doors & Drawers	\$ 107.19



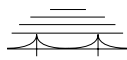

## JOINING TOOLS

### LAMELLO JOINTING BISCUITS

Beech



Oval jointing plates fit easily into slot & allow adjustment for perfect alignments without jigs. Dampness of glue swells plate to great strength. Made of compressed beech. Will join panels to 3/8" thick.

**Sold in full cartons only.**

Code	Size	Ctn	List/M
0LA	1-3/4" Plate	1000	\$ 89.40
10LA	2-1/8" Plate	1000	89.40
20LA	2-1/2" Plate	1000	89.40

### ECONOMY BIRCH BISCUITS

Porter Cable



Code	Size	Ctn	List/M
5551PC	1-3/4" Plate	1000	\$ 54.95
5552PC	2-1/8" Plate	1000	55.39
5553PC	2-1/2" Plate	1000	55.39

### LAMELLO PLATE JOINING TOOL - Special Order

Classic X  
List \$ 599



#### Special Order

A versatile biscuit joiner, Classic X installs 15 different Lamello joining elements, and it offers four additional applications besides biscuit and connector joining:

- Cutting of grooves for tongue and groove connections
- Cut expansion gaps for wood ceilings and floors
- Wood repairing of resin pockets and small defects
- Trimming of solid wood or plastic edges

#### Features:

- Powerful 780 watt motor
- Flush-sided swiveling front with notches at angles 22.5, 45 and 67.5 degrees
- Quick adjustment for 6 cutting depths
- Groove cutter with 6 alternating teeth
- Height adjustable flush-sided front stop square
- Anti-slip pads
- Central locking for quick change of cutter

### PLATE JOINER KIT

Model 557PC  
List \$ 471



- 7.5 Amps, 120 VAC
- Fence tilts from 0° to 135° with positive adjustable stop at 90°
- Precise micro height-adjustment knob for perfect placement of biscuits
- Includes both 2" and 4" diameter blades for standard and face-frame biscuits
- Lock-on trigger
- Seven position rotating depth-stop for FF, #0, #10, #20, Simplex, Duplex and Max (#6) biscuits
- Spindle lock for easy blade changes
- Includes plate joiner #557, 2" blade #5559, 4" blade #5558, centering plate #888776, spanner wrench #886041, dust bag #883175, chip deflector #886490, and operating manual

**FESTOOL**

**JOINERS/ACCESSORIES**

**Domino DF 500 Q Mortise and Tenon Joiner Set**

Domino Joiner DF 500 Q Set (including trim stop and cross stop) for fast, easy and strong mortise and tenon joining.

- Unique, patented cutting action that rotates and oscillates to create perfect, clean, and repeatable mortises every time.
- Mortise width adjustment with the turn of a dial allows for easier alignment when joining panels.
- Pivoting Fence allows you to create angled mortises from 0-90° with positive stops at 22.5°, 45°, 67.5°.
- Indexing pins for quick alignment against the edge of the workpiece for accurate placement.



**DOMINO DF 500 Q**

Includes:

- DOMINO cutter D 5
- Support bracket
- Wrench
- Plug-it cord
- Systainer
- Trim stop
- Cross stop

Code	Price
574432	\$ 950

**Beech Domino Tenons**



Large and Small cartons available

Code	Thick x Width x Length	Ctn Qty	Ctn
495661	4mm x 17mm x 20mm	450	\$ 22
493296	5mm x 19mm x 30mm	1800	88
493297	6mm x 20mm x 40mm	1140	88
493298	8mm x 22mm x 40mm	780	85
493299	8mm x 22mm x 50mm	600	88
493300	10mm x 24mm x 50mm	510	88
494938	5mm x 19mm x 30mm	300	22
494939	6mm x 20mm x 40mm	190	22
494940	8mm x 22mm x 40mm	130	22
494941	8mm x 22mm x 50mm	100	22
494942	10mm x 24mm x 50mm	85	22

**Sipo Wood Domino Tenons**



For Outdoor Applications. Made from African Mahogany. Resistant to moisture, decay, fungus and termites. Large and Small cartons available.

Code	Thick x Width x Length	Ctn Qty	Ctn
494859	5mm x 19mm x 30mm	900	\$ 102
494860	6mm x 20mm x 40mm	570	102
494861	8mm x 22mm x 40mm	390	102
494862	8mm x 22mm x 50mm	300	102
494863	10mm x 24mm x 50mm	255	102
494869	5mm x 19mm x 30mm	300	43
494870	6mm x 20mm x 40mm	190	42
494871	8mm x 22mm x 40mm	130	43
494872	8mm x 22mm x 50mm	100	43
494873	10mm x 24mm x 50mm	85	43

**Beech Stock Tenons**

Made to be cut-to-length



498686	8mm x 750mm	36	\$ 70
498687	10mm x 750mm	28	70

**Sipo Stock Tenons**

Made to be cut-to-length



498690	8mm x 750mm	36	\$ 102
498691	10mm x 750mm	28	102

**Beech Domino Tenon Assortment**

Assortment includes 5 Cutters, Domino Assortment Systainer, and 1060 tenons.



Tenon assortment:  
4 x 20mm (450), 5 x 30mm (225),  
6 x 40mm (150), 8 x 40mm (100),  
8 x 50mm (75), 10 x 50mm (60)

Cutter assortment:	Code	Price/Asst
D4mm (1), D5mm (1), D6mm (1), D8mm (1), D10mm (1)	498899	\$ 295.00

**Domino DF500 Cutters**

Carbide Tipped



Code	Description	Price
495663	For 4mm Tenons	\$ 37
493490	For 5mm Tenons	38
493491	For 6mm Tenons	39
493492	For 8mm Tenons	41
493493	For 10mm Tenons	42

**JOINERS/ACCESSORIES**

**FESTOOL**

**Domino XL DF 700 Mortise and Tenon Joiner Set**

Domino Joiner DF 700 EQ Set (including trim stop and cross stop) for fast, easy and strong mortise and tenon joining.

- Unique, patented cutting action that rotates and oscillates to create perfect, clean, and repeatable mortises every time.
- Mortise width adjustment with the turn of a dial allows for easier alignment when joining panels.
- Pivoting Fence allows you to create angled mortises from 0-90° with positive stops at 22.5°, 45°, 67.5°.
- Indexing pins for quick alignment against the edge of the workpiece for accurate placement.



**DOMINO XL DF 700**

Includes:

- DOMINO cutter D 12
- Support bracket
- Wrench
- Plug-it cord
- Systainer
- Trim stop
- Cross stop

**Code**                      **Price**  
574447                      \$ 1375

**Beech Domino Tenons**



Large and Small cartons available

Code	Thick x Width x Length	Ctn Qty	Ctn
493298	8mm x 22mm x 40mm	780	\$ 85
493299	8mm x 22mm x 50mm	600	88
493300	10mm x 24mm x 50mm	510	88
494940	8mm x 22mm x 40mm	130	22
494941	8mm x 22mm x 50mm	100	22
494942	10mm x 24mm x 50mm	85	22
498216	12mm x 26mm x 100mm	100	54
498217	12mm x 26mm x 140mm	90	54
498218	14mm x 28mm x 100mm	80	54
498219	14mm x 28mm x 140mm	70	54

**Beech Stock Tenons**

Made to be cut-to-length



498686	8mm x 750mm	36	\$ 70
498687	10mm x 750mm	28	70
498688	12mm x 750mm	22	70
498689	14mm x 750mm	18	70

**Sipo Stock Tenons**

Made to be cut-to-length



498690	8mm x 750mm	36	\$ 102
498691	10mm x 750mm	28	102
498692	12mm x 750mm	22	102
498693	14mm x 750mm	18	102

**Beech Domino Tenon Assortments**

**Assortment 8/10mm**

Includes 2 Cutters, Systainer, and 380 tenons.

Tenon assortment:  
8 x 50mm (48), 8 x 80mm (38),  
8 x 100mm (36), 10 x 50mm (82),  
10 x 80mm (52), 10 x 100mm (52)

Cutter assortment:  
8mm (1), 10mm (1)



**Code**                      **Price/Asst**  
498204                      \$ 295

**Assortment 12/14mm**

Includes 1 Cutter, Systainer, and 128 tenons.

Tenon assortment:  
12 x 100mm (40), 12 x 140mm (40),  
14 x 100mm (16), 14 x 140mm (32),

Cutter: 14mm



**Code**                      **Price/Asst**  
498205                      \$ 269

**Domino DF700 Cutters**

Carbide Tipped



Code	Description	Price
497868	For 8mm Tenons	\$ 54
497869	For 10mm Tenons	56
497870	For 12mm Tenons	58
497871	For 14mm Tenons	60

### SENCO NAIL GUNS

#### SENCO BRAD NAILER - SLP20XP



**SLP20XP**  
Height: 8-1/4"  
Length: 9-1/2"  
Lip Length: 3/4"  
Magazine Capacity: 110  
Operating Pressure: 70-120 psi  
Mode of Operation: Restrictive Trigger  
Hose Fitting: 1/4" NPT

List \$ 267.92

Drives both slight & medium headed brads. Fastener range 5/8" - 1-5/8". Use with AY10, AY11, AY13, AX13, AX15, AX17, AX18.

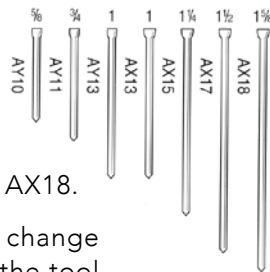

Easy side loading allows you to change brad lengths without adjusting the tool. Lightweight 2.3 lbs for easy handling and maneuvering. Oil-free design. Comfort-grip handle.

Applications: cabinets, furniture, woodworking, mobile home and RV construction.

#### SENCO HEADLESS BRAD NAILER - LS1XP



**LS1XP**  
Molding & Decorative Trim, Furniture Trim, Blind Pinning of Upholstered & Trim Panels, Rattan and Picture Frames.

List \$ 720.59

Drives 18 Gauge Headless Pins AZ08 - AZ13: 1/2"-1" Cap: 100.

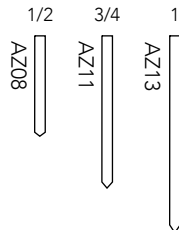

Weighs only 2.9 lbs. - light for easy handling. Bottom loading magazine for quick loading. Comfort-grip handle. Oil-free design means no lubrication to stain fine woods. Rugged composition enables magazine to withstand on-the-job stress. Muffler ensures quieter operation.

#### SENCO FINISH NAILER - SFN30



Weight: 3.6 lbs  
Height: 9-5/8"  
Length: 12"  
Capacity: 104  
Pressure: 70-120 psi  
Drive range: 1" - 2"

List \$ 437.76

Drives: DA13 (1"), DA15 (1-1/4"), DA17 (1-1/2"), DA19 (1-3/4"), DA21 (2")

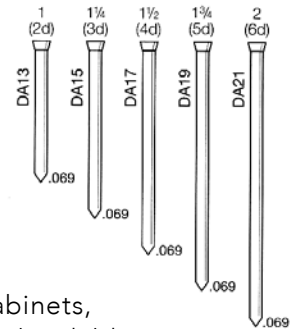

Applications: Furniture and cabinets, picture frames, construction and nailable plastic parts.

Features: Lightweight, oil-free, adjustable depth-of-drive, and belt hook adjusts to RH and LH. Case included.

#### SENCO FINISH NAILER - FP42XP



Weight: 4.7 lbs  
Height: 11-1/4"  
Length: 13"  
Magazine Capacity: 104  
Pressure: 70-120 psi  
Drive range: 1-1/4" - 2-1/2"

List \$ 407

Drives: DA15 (1-1/4"), DA17 (1-1/2"), DA19 (1-3/4"), DA21 (2"), DA23 (2-1/4"), DA25 (2-1/2")

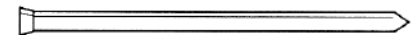

Applications: Window and door casings, cabinets, furniture, woodworking, molding, paneling and picture frames.

Features: Superior power, adjustable depth-of-drive, oil-free design, no-mar pad increases visibility to help accurate nail placement, low recoil. Case included.



**SENCO GUNS**

**MODEL SLS20**

Upholstery, cabinets, casebacks, insulative sheathing, lattice. Adjustable depth-of-drive. Oil-free tool.



**SLS20-L** List \$ 440.66  
Crown: 1/4"  
Lengths: 3/8" to 1-1/2"  
Capacity: 168

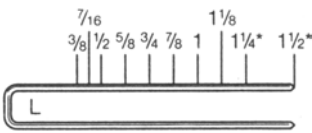

L06-L17

**SLS20-M** List \$ 428.66  
Crown: 3/8"  
Lengths: 3/8" - 1-1/2"  
Capacity: 140-240

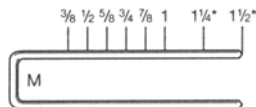

M06-M17

See Staples pg. 1803

**MODEL SKS-L**

For cabinet/furniture assembly, door and window casings, trim, moldings, aluminum and vinyl siding, roof sheathing and decking. Lightweight (2.3 lbs.). Comfort grip handle and oil free design.



List \$ 521

Crown Width: 1/4", 7/8" to 1-1/2" lengths  
Capacity: 145-158

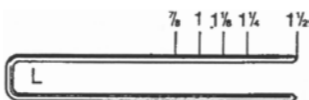

L12-L17

See Staples pg. 1803

**FINISH PRO 23 & 23L MICRO PINNER**



**FP23 MICRO PINNER**  
23 gauge, 1/2 to 1-3/8"

List \$ 326.20

**FP23L MICRO PINNER**  
23 gauge, 1/2 to 2"

List \$ 474.61

23 Gauge Pins, Galv.

Code	Length	Box Qty	Case	List/bx
A100509	1/2"	2600	5	\$ 17.38
CZ08EAA	1/2"	15500	4	103.94
A100629	5/8"	2600	5	16.44
CZ10EAA	5/8"	15500	4	107.92
A100759	3/4"	2600	5	17.38
CZ11EAA	3/4"	15500	4	113.54
A101009	1"	2600	5	15.43
A101259	1-1/4"	2600	5	16.95
A101379	1-3/8"	2600	5	36.28
A101509	1-1/2"	2600	5	17.90



**FP18 BRAD NAILER**  
18 gauge, 5/8 to 2-1/8"  
2.48 lbs, Oil Free

List \$ 149.63



**FP25 BRAD NAILER**  
18 gauge, 5/8 to 2-1/8"  
2.7 lbs, Oil Free

List \$ 374.07

18 Gauge Brad Nails, Galv.

AY10	5/8"	5000	24	\$ 29.53
AY11	3/4"	5000	20	30.98
AY13	1"	5000	16	34.41
AX13	1"	5000	16	18.20
AX15	1-1/4"	5000	12	16.52
AX17	1-1/2"	5000	10	18.42
AX18	1-5/8"	5000	10	34.34
AX19	1-3/4"	5000	5	32.30
A202009	2"	800	5	9.64
AX21EAAN	2"	5000	6	51.07



**SENCO GUNS**

**GREX PINNERS**

**FP35 BRAD NAILER**



Weight: 4.65 lbs  
Height: 12-1/4"  
Length: 13"  
Magazine Capacity: 110  
Pressure: 70-120 psi  
  
15 gauge  
Drive range:  
1-1/4" - 2-1/2"

List \$ 427.53

Drives:

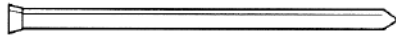

DA15 (1-1/4"), DA17 (1-1/2"), DA19 (1-3/4"), DA21 (2"),  
DA23 (2-1/4"), DA25 (2-1/2")

**GREX TOOLS**

Headless Pinners and Pins

**23 Gauge Headless Pinner**

Code	Description	List/ea
P635	3/8" - 1-3/8" Pinner	\$ 372.40
P650	3/8" - 2" Pinner	578.54



- Pins are set 1/16" below material surface
- Magazine automatically adjusts for pin size
- Magazine angled rear cut-off allows for placement into corners
- Narrow nose design for reaching into tight areas
- No-mar rubber tip protects surfaces (two included)
- Fastener indicator window shows when fasteners are low
- Rear exhaust w/ silencer
- Dual trigger safety system
- Quick access storage for no-mar tip and hex wrench
- Belt Hook
- Lightweight - 2.2 lbs.

**Headless Pins / Med Head Brads**

**P6 Series**  
23 gauge  
Headless pins  
10,000/box

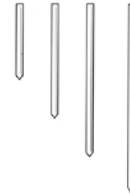

**GBN Series**  
18 gauge  
Brad Nails  
Medium  
Head  
5,000/box

Code	Description	List/bx
P6/10L	3/8" Headless Pins	\$ 13.70
P6/12L	1/2" Headless Pins	14.10
P6/15L	5/8" Headless Pins	12.06
P6/20L	3/4" Headless Pins	18.65
P6/22L	7/8" Headless Pins	19.33
P6/25L	1" Headless Pins	19.11
P6/28L	1-1/8" Headless Pins	21.81
P6/30L	1-3/16" Headless Pins	23.38
P6/35L	1-3/8" Headless Pins	22.56
P6/38L	1-1/2" Headless Pins	33.16
P6/40L	1-9/16" Headless Pins	36.52
P6/45L	1-3/4" Headless Pins	38.67
P6/50L	2" Headless Pins	45.21
GBN18-15	5/8" Brad Nails	22.90
GBN18-25	1" Brad Nails	27.59
GBN18-32	1-1/4" Brad Nails	29.10
GBN18-38	1-1/2" Brad Nails	30.46
GBN18-50	2" Brad Nails	31.23

**SENCO PARTS**

**PLUGS & COUPLERS**

(Do not use with Industrial Interchange Design)

**1/4" PLUG,  
MALE PIPE THREAD**  
Plated Steel, Carded



<u>Code</u>	<u>Size</u>	<u>Card</u>	<u>List/cd</u>
1601DL	1/4"	1 ea.	\$ 3.76

**1/4" COUPLER,  
MALE PIPE THREAD**  
Brass, Carded



<u>Code</u>	<u>Size</u>	<u>Card</u>	<u>List/cd</u>
162DL	1/4"	1 ea.	\$ 10.01

**1/4" PLUG,  
FEMALE PIPE THREAD**  
Plated Steel, Carded



<u>Code</u>	<u>Size</u>	<u>Card</u>	<u>List/cd</u>
1602DL	1/4"	1 ea.	\$ 3.47

**1/4" COUPLER,  
FEMALE PIPE THREAD**  
Brass, Carded



<u>Code</u>	<u>Size</u>	<u>Card</u>	<u>List/cd</u>
160DL	1/4"	1 ea.	\$ 9.81

**1/4" COUPLER,  
LOCKING HOSE BARB**  
Brass, Carded



<u>Code</u>	<u>Size</u>	<u>Card</u>	<u>List/cd</u>
163L	1/4"	1 ea.	\$ 13.14

**INDUSTRIAL INTERCHANGE**

**PLUGS & COUPLERS**

(Do not use w/Tru-Flate Design)

**PLUG - Male Pipe Thread**

<u>Code</u>	<u>Size</u>	<u>Pk</u>	<u>List/pk</u>
PC0479	1/4"	2 ea.	\$ 3.87
PC0480	3/8"	2	6.12



**COUPLER - Male Pipe Thread**

<u>Code</u>	<u>Size</u>	<u>Pk</u>	<u>List/pk</u>
PC0503	1/4"	1 ea.	\$ 8.34



**PLUG - Locking Hose Barb**

<u>Code</u>	<u>Size</u>	<u>Pk</u>	<u>List/pk</u>
PC0576	1/4"	2 ea.	\$ 3.78



**PLUG - Female Pipe Thread**

<u>Code</u>	<u>Size</u>	<u>Pk</u>	<u>List/pk</u>
PC0477	1/4"	2 ea.	\$ 3.86



**COUPLER - Female Pipe Thread**

<u>Code</u>	<u>Size</u>	<u>Pk</u>	<u>List/pk</u>
PC0501	1/4"	1 ea.	\$ 6.62



**COUPLER - Locking Hose Barb**

<u>Code</u>	<u>Size</u>	<u>Pk</u>	<u>List/pk</u>
PC0505	1/4"	1 ea.	\$ 10.10



**SENCO PARTS**

**HOSE WITHOUT FITTINGS**

Quick couple packaged hose.



<u>Code</u>	<u>Size</u>	<u>Ctn</u>	<u>List/ea</u>
PC0045	1/4" x 50'	1	\$ 61.74

**HOSE**

1/4" male pipe thread ends. Use with female pipe thread fittings.



<u>Code</u>	<u>Size</u>	<u>Ctn</u>	<u>List/ea</u>
PC0059	1/4" x 50'	1	\$ 87.57

**SENCO PVC AIR HOSE**

1/4" x 50' packaged hose with MPT threaded.



<u>Code</u>	<u>Size</u>	<u>Ctn</u>	<u>List/ea</u>
PC0075	1/4" x 50'	1	\$ 40.30

**SENCO PARTS KITS**

Carded parts kits for Senco tools.  
Pack: 1 card.



<u>Code</u>	<u>Description</u>	<u>Tool</u>	<u>List/cd</u>
EC0215	C-Driver	LS	\$ 32.54
EC0178	3/16" CSK Driver	SKS	33.30
YK0180	B-Lower -Rings	SLP20	54.80
YK0373	Repair Kit	SLP20	73.54
YK0376	Repair Kit	SFN1, SKS, SPS	87.90

**SENCO PNEUMATIC TOOL OIL**

Pack: 1 each

<u>Code</u>	<u>Size</u>	<u>List/ea</u>
PC0101	1/2 pint	\$ 4.00
PC0102	Quart	9.70



**HOSES**

**DYNASWIVEL AIR LINE CONNECTOR**

Never Fight an Air Hose Again!

**The Problem**



**The Solution**



The Dynaswivel is a patented "universal-joint" that connects portable air tools to an air line. Swivels 360° at two pivot points allowing the air hose to drop directly to the floor while providing superb tool handling. Improves tool maneuverability, minimizes operator fatigue and extends hose life.



Thread Size: 1/4" NPT (6mm)  
Air Flow Range (LPM): up to 33SCFM (9935)

<u>Code</u>	<u>Description</u>	<u>List/ea</u>
94300	Dynaswivel Air Hose Connector	\$ 30.24

**"FLEXEEL" FLEXIBLE Polyurethane Hose**

Coilhose Pneumatic



PFE40254TR  
Red / 25'



PFE40504T  
Blue / 50'

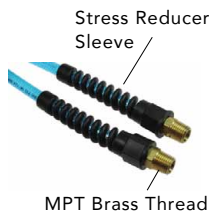

Transparent Polyurethane hose with dacron polyester inner braid reinforcement. Most flexible user-friendly air hose on the market. Low wear, less resistance to movement than traditional air hoses, naturally flexible, easy to coil. Extremely abrasion resistant, UV stabilized. Temperature range: 40° F to 165° F. 1/4" male pipe thread both ends.

<u>Code</u>	<u>Description</u>	<u>List</u>
PFE40254TR	Red, 1/4" ID x 25'	\$ 32.41
PFE40504T	Blue, 1/4" ID x 50'	54.71

**BLOW GUNS**

**TYPHOON BLOW GUN**

Coilhose Pneumatic

TYP2500CS



The Typhoon Blow Gun is ideal for heavy-duty clean-up and blow-off.

Meets or exceeds OSHA regulations. Variable flow trigger for controlled blow-off. Comes with a High Flow nozzle. 34 CFM @ 125 PSI, 2.1 lbs of thrust.

Has a 1/4" NPT (National Pipe Thread) in-port.

<u>Code</u>	<u>Description</u>	<u>List/ea</u>
TYP2500CS	High flow Blow Gun	\$ 31.58

**TYPHOON "PRO" BLOW GUN**

Coilhose Pneumatic



All-metal design for high volume users. Chrome plating on an aluminum body resists chemicals and solvents. Easy to clean.

Variable flow control for precise air delivery. Silicone free so ideal for use in paint applications. Lightweight aluminum body with a rugged, chrome-plated brass High Flow nozzle. 34 CFM @ 125 PSI, 2.1 lbs of thrust. OSHA compliant.

<u>Code</u>	<u>Description</u>	<u>List/ea</u>
2501CS-TYP	All Metal Blow Gun	\$ 49.82

# CASTLE

# POCKET CUTTER MACHINES

## TABLE TOP POCKET CUTTER

## AUTOMATIC POCKET CUTTER



**TSM-12**

\$ 1125 Net



**TSM-21**

\$ 3215 Net

This portable manual cycle pocket cutter was designed for fast assembly of face frames and cabinet panel construction. It offers the same drilling pattern as the larger unit (TSM21).

- Fast, hand-operated cycle; pockets can be done in less than 2 seconds.
- Works well in high-pressure plastic laminate particle board, MDF, melamine and solid wood 1/2" to 1-1/2" thick.

Supplied with: 3/8" Universal carbide router bit, and 9/64" stub-flute cobalt aircraft drill bit - 1/4" shank. Power Requirements: 120 VAC, 15 amps. No air supply needed.

The Castle Pocket Cutting Machine first routes a clean pocket and then drills a pilot hole from the edge to the pocket at 6°. This low screw angle produces very little shifting force, which eliminates the requirement for expensive and space consuming clamping systems. The low screw angle reduces screw breakout and splitting which saves sanding belts and minimizes rejects.

### TSM-12, TSM21 and TSM35

### Features:

**PATENTED METHOD:** Patent No. 4603719

- 1.75 HP, 110 VAC, 15 amps, 85 PSI
- Fast - Automatic cycle adjustable to less than 2 seconds per cycle
- Safe - Will not cycle unless material is inserted completely
- Works well in high pressure plastic laminate, particle board, MDF, Melamine and solid wood 1/2" to 1-3/4" thick.

Assemble face frames and panels with less clamping and better alignment.

- Router: Porter-Cable 1.75 HP #6902
- Router Bit: Premium 3/8" Solid Carbide, Rough Mill
- Drill: Porter Cable Trimmer Motor #7301
- Drill Bit: 9/64" Brad and Spur Premium TiN Coated Bit
- Power Req: 110 VAC, 15 amps
- Air Req: 1 cfm at 85 psi
- Shipping Wt: 160 lbs.

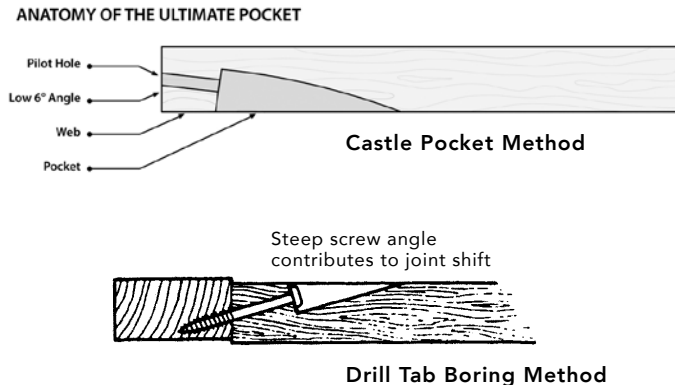

The low screw angle of the Castle Pocket method reduces screw breakout and splitting which saves sanding belts and minimizes rejects.



**POCKET CUTTER MACHINES**

**ACCESSORIES**

**AUTOMATIC POCKET CUTTER - Heavy Duty**  
Castle Tool

**TSM-35**

\$ 6495 Net



The Model TSM35 Heavy Duty Screw Pocket Cutting Machine has been designed for continuous operation in a heavy production environment. First it routes a clean pocket and then drills a pilot hole from the edge to the pocket at 6°. The low screw angle produces very little shifting. It also reduces screw break-out and splitting, which saves sanding belts and minimizes rejects.

**FAST** - Fast cycle time for speedy production.  
**SAFE** - Will not cycle unless material is inserted completely.

Easy top-down access for quicker router and drill bit changes.  
Adjustable Indexing-Stops in top for face frame parts.  
Side brackets allow mounting of wing tables.

- Router: 1-1/2 HP Baldor Router Motor
- Router Bit: Premium 3/8" Solid Carbide, Rough Mill
- Drill: Sioux SDG10S25FCT Air Motor
- Drill Bit: 9/64" Brad and Spur Premium TiN Coated Bit
- Power Req: Three-phase 208v, 230v, 460v
- Air Req: 85 psi - External Regulator, Filter and Lubricator included
- Shipping Wt: 300 lbs.

**CASTLE TOOL ACCESSORIES**

**Pilot Hole Drill Bits**



B00764 - 7/64" Split Point: Recommended for use with #7 screw for a very snug fit, requiring a driver for insertion.



B00964 - 9/64 Brad Point: The standard bit that ships with Castle Pocket Cutters. The brad point tip tracks well in all kinds of materials, suitable for the majority of pocket cutting needs. Best used with a #7 screw.



B00316 - 3/16 Drill Bit: Best used with a #8 screw in soft woods or materials such as melamine.

**Premium Carbide Router Bit**



B00338 - Comes standard with all new Castle machines. Designed for both hard and soft woods, leaving a clean, splinter free pocket. Excellent for cutting MDF, Melamine, Laminates, and other composites. Lasts 3-5 times longer than other rough mills.



B03055

**Line Boring Spade Bit**

Patented, solid carbide, super duty, line boring bit. For the 23 and 30 Castle line boring machines.



B40005

**Case Clamp**

Case Clamp for Case & Panel Clamping Stock for Screw pocket Joinery.

Code	Description	List/ea
B00764	Pilot Bit, 7/64"	\$ 16.10
B00964	Pilot Bit, 9/64"	16.10
B00316	Pilot Bit, 3/16"	16.10
B00338	Carbide Spiral Bit	129.00
B03055	Line Boring Bit	56.00
B40005*	Case Clamp	60.21

\*disc when out

6" Power Bit. Available in Phillips or Square Drive.



Code	Description	List/ea
12694	6" Phillips Drive #2	\$ 5.98
12698	6" Square Drive #2	5.74



## CASTLE ASSEMBLY TABLES



### **AT-5OB OPEN BACK ASSEMBLY TABLE**

**Special Order**

**\$ 3595 Net**

The AT-5 OpenBack assembly table is built using the same dimensions and features as the standard AT-5, except it has an open beam for the clamping arm to ride on.

With the arm riding on the beam, the way is clear to extend face frames up, beyond the top of the table. This means face frames of six or seven feet in height are no longer a problem! Useful in the construction of vanities, entertainment centers, and custom cabinetry. (Screw gun not included.)

### **Standard Features of the AT-5 and AT-5 OB**

- Sturdy 4' x 5' work surface.
- Low squaring fence accommodates frames beyond the length of the work surface.
- Bottom rail is a comfortable height of 32" to reduce operator fatigue.
- Smooth one-hand action of each cylinder allows for rapid positioning and clamping.
- Extra-rigid beam is equipped with air regulator and pressure gauge.
- Convenient air hose at lower end of beam for air screw gun.
- Heavy duty casters available.
- Convenient screw tray is just inches away from the work at all times.
- Air requirements are 85 psi and less than 1 cfm.

---

---

---

---

---

---

---

---

---

---

---

---

---

---

---

---

**CASTLE ASSEMBLY TABLES**



**AT-8OB OPEN BACK ASSEMBLY TABLE**      **Special Order**      \$ 4425 Net  
 4' x 8' Work Surface

The AT-8 OpenBack assembly table is built using the same dimensions and features as the standard AT-8, except that it comes equipped with an open beam for the clamping arm to ride on. With the arm riding on the beam, the way is clear to extend face frames up, beyond the top of the table. This means face frames of six or seven feet in height are no longer a problem! This is especially useful in the construction of vanities, entertainment centers, and custom cabinetry. The OpenBack tables open up the possibilities and shorten the construction time for difficult to handle jobs. (Screw gun not included.)

Features

- Sturdy 4' x 8' work surface.
- Low squaring fence accomodates frames beyond the length of the work surface.
- Bottom rail is a comfortable height of 32" to reduce operator fatigue.
- Smooth one-hand action of each cylinder allows for rapid positioning and clamping.
- Extra-rigid beam is equipped with air regulator and pressure gauge.
- Convenient air hose at lower end of beam for air screw gun.
- Heavy duty casters available.
- Convenient screw tray is just inches from the work at all times.
- Air requirements are 85 psi and less than 1 cfm.

---

---

---

---

---

---

---

---

---

---

---

---

**COVER CAPS**

**ADHESIVE-BACKED CASTLE COVER CAPS**

Fastcap

Self-adhesive cover caps to cover holes cut by Castle Pocket Cutter machinery.

Available in PVC colors or real wood veneer.

9/16" x 2-1/2" caps, 1/32" Thick.

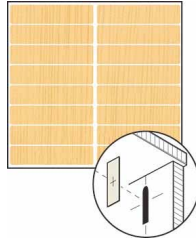

- Easy to use. They stay in place the first time you stick them over the screw hole.
- They do not depend on the head of the screw for adhesion
- The screw can be sunk far below the surface of the material and FastCaps will cover the hole effectively

Pack: 16 caps per sheet, 320 caps per box  
Please order in increments of 16!

PVC	Color	List/C
FC-WH-CC	White	\$ 15.99
FC-BL-CC	Black	15.99
FC-AL-CC	Almond	16.03
FC-NO-CC	Natural Oak	20.02
FC-HM-CC	Hard Rock Maple	20.02
FC-MW-CC	Mahogany on Walnut	20.04
FC-NC-CC	Natural Cherry	20.02
FC-BC-CC	Bourbon Cherry	20.04

**Real Wood**

FC-MAP-CC	Maple	27.55
FC-CH-CC	Cherry	28.92
FC-RO-CC	Red Oak	28.92

**Real Wood, Finished**

FC-MP-CCF	Maple	35.18
FC-CH-CCF	Cherry	33.58

**SCREW HOLE CAPS FOR CASTLE POCKET CUTTERS**

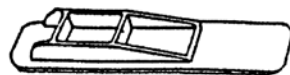

Screw hole caps to fill the holes drilled by Castle Pocket Cutters for face-frame assemblies.

Code	Color	Ctn	List/M
1924WH	White	1000	\$ 94.16
1924ALM	Almond (Beige)	1000	98.04

**BOSCH HEAT GUN**

Model 1942



1942BO  
List \$ 263.88

Rating.....115V AC  
Amperage.....14.3  
Max. Temperature.....1,000  
Max. Air Volume.....23 C.F.M.  
Length.....12"  
Weight.....3.5 lbs.

3-wire grounded, UL listed, complies to OSHA.

- For continuous duty, industrial, and commercial applications
- Air intake regulator allows variable temperature adjustment
- Insulated nozzle allows cool exterior temperature
- Padded, adjustable stand can be positioned for any work angle

**FESTOOL HL 850 PLANER**



The HL 850 E lets you cut flush to an adjacent surface because it can plane across the entire width of the rebate.

Safe design. The side guard swings up as the rebate depth increases. Planing up to the edge in deep rebates is no longer a problem.

574553

Power consumption.....850 watts/ 7 amps 120 V AC  
Drive Shaft speed.....10,000 rpm  
Cutting depth.....0 - 9/64" (0 - 3.5mm)  
Rebating depth.....unlimited  
Head width.....3-15/64" (82mm)  
Noise level at idle.....79 dB (A)  
Weight.....8.6 lbs. (3.9 kg)

**HL 850 E Includes:**

	Code	Price
• Parallel Stop	574553	\$ 640
• Standard Planer Head		
• Solid Carbide Standard Blade		
• Rabbet Depth Guide		
• Systainer		

**CORDLESS DRILLS**

**BOSCH ULTRA COMPACT SCREWDRIVERS**

Litheon Battery - Smaller, Lighter Tools!



**PS10-2**  
List \$ 323.10

Bosch Litheon ultra-compact tools use 10.8 volts - enough to complete 80% of a pro's typical applications - in a package up to 50% smaller than most drill/drivers. Smaller and Lighter. All the power you need for most of the work you do.

**BOSCH PS31-2A 12V DRILL DRIVER**

Cordless

Model	PS31-2A
Rating	12 Volt
No Load RPM	0-350/0-1.300
Max Torque	265 lbs.
Chuck capacity	3/8"
Clutch settings	20 + 1
Length	7"
Weight	2.14 lbs.



PS31-2A



- Lightest Weight in its Class
- Best Performance to Size Ratio
- Equipped with 3/8" Single Sleeve Chuck
- LED Light - Enables use of tool in low light or dark areas
- 20 + 1 Clutch Settings - For precise torque adjustment
- Forward/Reverse Button - Equally useful at driving or removing screws
- Light weight - Great for overhead continuous work
- Compactness - Small enough to reach into tight areas and corners

Includes: (2) Lithium Ion 12V Max Batteries, 30 Minute Charger, Carrying Case

Code	Description	List/ea
PS31-2A	Drill Driver 12 V, 3/8"	\$ 297.23

**BOSCH DDB180 18V COMPACT DRILL/DRIVER**

Cordless, For Light Duty applications



Model	DDB180
Rating	18 Volt
No Load RPM	0-400/0-1.300
Max Torque	400 lbs.
Chuck capacity	3/8"
Clutch settings	15 position
Length	7.7"
Weight	3.0 lbs.



DDB180

- Extremely Compact and Lightweight with Professional Grade Performance
- Slim-Diameter Soft Grip Handle - less user fatigue
- Bosch Lithium-Ion - combines Electronic Cell Protection, unique battery pack design, and customized electronics to deliver optimal battery life and performance
- Keyless Single Sleeve 3/8" Chuck - For easy, one-handed bit changes
- LED Light - Great for dark or enclosed areas

Includes: (2) Lithium Ion SlimPack Batteries, Fast Charger, Double Ended Bit, Carrying Case

Code	Description	List/ea
DDB180	Drill Driver 18 V, 3/8"	\$ 346.77

**FESTOOL C12 CORDLESS SCREWDRIVER**

Compact & light-weight design never needs more than 6" of space.

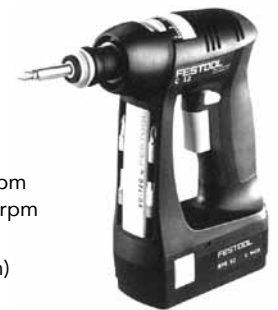

Battery voltage.....	12 V
Idling speed.....	setting 1: 0 - 450 rpm setting 2: 0 - 1500 rpm
Chuck capacity.....	1/2" (13mm)
Max drilling dia.....	steel: 9/16" (14mm) wood: 1" (25mm)
Weight/charging time.....	1.3 Ah NiCD: 3 lbs 6.8 oz / 25 min 3.0 Ah NiMhd: 3 lbs 13.4 oz / 70 min

**C12 Includes:**

LC 45 charger; 2 NiCD batteries; FastFix® keyless chuck; Centrotec® starter set; in Systainer 1. With both right angle and eccentric FastFix® chucks.

Code	Description	Price
PC1213S	1.3AH	\$ 470
PC1230S	3.0AH	520



**LAMINATE TRIMMERS**

**ROUTERS**

**PORTER CABLE LAMINATE TRIMMERS**

**PCE6430**

Laminate Trimmer, 1/4"

- 4.6 lbs. weight
- 31000 RPM, 4.5 amp motor
- Precision-machined, cast-aluminum fixed base
- Extra large locking clips allow for a quick motor release and/or course depth adjustment
- Depth ring enables quick and accurate bit height adjustments
- Spindle lock button allows for single-wrench bit changes



PCE6430

**Includes:**

- (1) Standard fixed base
- (1) 1/4-inch collet
- (1) Collet wrench
- (1) Straight edge guide

<u>Code</u>	<u>List/ea</u>
PCE6430	\$ 200.18

**PCE6435**

Laminate Trimmer, 1/4"

- 5.2 lbs. weight
- 16000-35000 RPM, 5.6 amp motor
- Precision-machined, cast-aluminum fixed base
- Extra large locking clips allow for a quick motor release and/or course depth adjustment
- Depth ring enables quick and accurate bit height adjustments
- Spindle lock button allows for single-wrench bit changes



PCE6435

**Includes:**

- (1) Standard fixed base
- (1) 1/4-inch collet
- (1) Collet wrench
- (1) Straight edge guide

<u>Code</u>	<u>List/ea</u>
PCE6435	\$ 284.09

**BOSCH COMPACT 1.0 PALM ROUTER**



Single Speed: PR10E  
Variable Speed: PR20EVSK



**Specifications:**

Horsepower:	1.0	Fixed Base Opening/
Voltage:	120V	Max Bit Diameter:
Amp Rating:	5.7 A	1-9/16" / 1-15/16"
Frequency:	50-60 Hz	Height:
Collet Type:	1/4" SR	Weight:
		3.3 lbs.
Single Speed (PR10):	n <sub>0</sub> 35,000 RPM	
Variable Speed (PR20):	n <sub>0</sub> 16,000 - 35,000 RPM	

<u>Code</u>	<u>Description</u>	<u>List/ea</u>
PR10E	Single Speed Palm Router	\$ 211.92
PR20EVSK	Var. Speed, Case Included	243.09



**ROUTERS**

**PORTER CABLE  
1-3/4 HP ROUTER**

Model 690LR  
List \$ 357.32

- New auto-release collet system ends "frozen bits"
- Dust proof switch
- Precision machined aluminum motor housing & base
- Accurate micrometer depth-of-cut adjustment
- 100% sealed ball-bearings
- Lever release height adjustment
- Standard Equipment: Router motor #6902, base #1001, 1/4" collet #42999, 1/2" collet #42950, collet wrenches #42596, and operating manual



**Specifications:**

Power.....120VAC, 25-60Hz  
Horsepower.....1-3/4 Collets-  
Motor Amps.....10 Standard....1/4" & 1/2"  
Speed (RPM).....23,000 Available.....3/8"  
Height.....8" Net Weight.....8 lbs.

**BOSCH VARIABLE SPEED  
2-1/4" HP ROUTER**

Model 1617EVS  
List \$ 364.47

- Exclusive Precision Centering System design; accurate, repeatable cuts at any depth setting.
- Microfine bit depth adjustment with resettable indicator ring.
- Adjustable sub-base allows precise centering for pattern work.
- Strong, lightweight all-magnesium construction.
- Precision self-extracting collet system.
- Quick templet guide change lever.



**Specifications:**

Power.....120VAC Base (opening) 3-3/4", (dia) 6"  
Horsepower.....2.25 Collet Capacity:  
Motor Amps.....12 1/4", 3/8", 1/2", 8mm  
No Load RPM...8,000-23,000 Weight.....8.3 lbs.

**Includes**

1/4" S. R. Collet Chuck.....2 610 906 283  
1/2" S. R. Collet Chuck.....2 610 906 284  
16mm Shaft Wrench.....2 610 991 388  
24mm Collet Nut Wrench.....2 610 992 417  
Chip Shield.....2 610 991 389  
Tool-Free Templet Guide Adapter.....2 610 991 370

**PORTER CABLE  
1-3/4 HP "D" HANDLE  
ROUTER**

Model 691PC  
List \$ 403.82

- New auto-release collet system ends "frozen" bits
- Precision machined aluminum motor housing & base
- Accurate micrometer depth-of-cut adjustment
- 100% sealed ball-bearings
- Dust proof switch
- **Standard Equipment:** Router motor #6912, base #6911, 1/4" collet #42999, 1/2" collet #42950, collet wrenches #42596, and operating manual



**Specifications:**

Power.....120VAC, 25-60Hz Collets:  
Horsepower.....1-3/4 Standard....1/4" & 1/2"  
Motor Amps.....11 Available.....3/8"  
Speed (RPM).....23,000 Net Weight.....10.25 lbs  
Height.....8"

**ROUTER TEMPLT GUIDES**

Porter Cable

Stocking guides.  
Use 42024 and 42237  
with Soss Hinges.



42024 List \$ 10.53      42045 List \$ 11.19      42237 List \$ 6.15

Code	Description	ID	OD	Distance past base
42024	Lock face routing	21/32"	3/4"	9/16"
42045	Use with Stanley T-3 template	17/32"	5/8"	9/16"
42237	Lock nut for all template guides			

**Special Order:**



Code	Description	ID	OD	Distance past base
42027	1/2" dovetailing and general routing	11/32"	7/16"	5/32"
42033	General routing	13/32"	1/2"	5/16"
42042	Hinge Butt routing	5/8"	51/64"	9/16"

**FESTOOL**

**ROUTERS**

**OF 1010 EQ Plunge Router**

A handy little plunge router that fits your hand like a glove. True one-handed operation; switch it on and off, plunge, cut and retract with ease.



574339

A compact design and efficient center of gravity make this tool extremely maneuverable. Its microadjustable depth control is accurate to 1/256" (1/10 mm).

The lightest router of its kind.

Power consumption.....	1010 watts/ 8.5 amps 120 V AC
Drive Shaft speed.....	10,000 - 23,000 rpm
Quick depth adjustment range...	2-3/16" (55mm)
Collet dia. range.....	1/4" and 8mm
Weight.....	5.94 lbs. (2.7 kg)

**OF 1010 Includes:**

- 8mm and 1/4" collets
- Collet wrench
- Chip catcher
- Dust extraction hood
- Guide rods/stop
- Standard U.S. guide bushing adaptor
- Plug-it cord
- Systainer

	<u>Code</u>	<u>Price</u>
	574339	\$ 435

**PLUG-IT REPLACEMENT POWER CORDS**

16 and 18 gauge

- 13 feet long
- Easily replace damaged or worn cords with the plug-it system
- By using a single cord:
  - save time switching between tools
  - minimize tangles and trip hazards
- Faster and easier to store and transport



<u>Code</u>	<u>Description</u>	<u>Price</u>
490656	16 gauge cord for use on TS55/TS75 Saws, OF1010/1400/MFK Routers	\$ 46
490649	18 gauge cord for use on Jigsaws, DF500 Domino, & Sanders	43

**MFK 700 EQ Router**

574368



**Includes:**

- 8mm and 1/4" collets
- Vertical Base
- 1.5° Horizontal Base
- Dust extraction hood
- Feeler Bearing Set
- Standard threaded base for U.S. Guide Bushing
- Plug-it cord
- Systainer

<u>Code</u>	<u>Price</u>
574368	\$ 525

Power consumption.....	720 watts/ 6.0 amps 120 V AC
Drive Shaft speed.....	10,000 - 26,000 rpm
Column Stroke.....	9/16" (14mm)
Max Bit dia.....	1" (26mm)
Weight.....	4.2 lbs. (1.9 kg)

Precision and flexibility in a trim router. With its modular design and tool-less base changes, the MFK 700 can easily transform from a vertical to a horizontal position with a few simple steps.

Trim laminate and edge band or rout grooves for inlays easily with its light weight and maneuverable. Allows you to use bearing-less bits when used with the attachable base feeler bearing. 1/256" (1/10 mm) fine depth adjustments and exceptional dust extraction make this an ideal router for all of your light routing tasks. For greatest range of adjustment a 3/4" (19 mm) bit diameter is recommended.

**RADIUS ROUTER BITS**

For use with the Festool MFK 700 Trim Router, this router bit produces the perfect radius on wood or plastic edge banding. The cutters can be rotated, prolonging service life with four new cutting surfaces. Diameter (D) of 28mm and cutting length (NL) of 3mm.

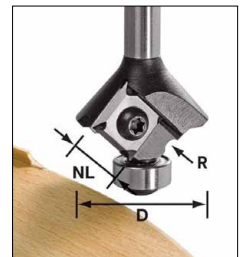

<u>Code</u>	<u>Description</u>	<u>Price</u>
499808	Router Bit, 3mm radius	\$ 135
499809	Radius Bit, 2mm radius	135
499810	Radius Bit, 1.5mm radius	135
499811	Radius Bit, 1mm radius	135



**ROUTERS**



**3-1/4 HP 5-SPEED  
SPEEDMATIC®  
PRODUCTION ROUTER**



Model 7518PC  
List \$ 772

**Standard equipment includes:** #75182 motor, #75361 base, #42591 1/2" collet, #42596 wrenches (2), and operating manual.

- Precision die-cast machined aluminum motor housing and base. Split base construction.
- Micrometer depth-of-cut control
- 7" round replaceable non-marking sub-base
- Insulated motor; no grounding required
- Built-in overload protection

**Specifications:**

Double Insulated	
Power.....120VAC, 60Hz	Base Diameter..... 7"
Horsepower..... 3-1/4	Collets (Split-Type)-
Motor Amps.....15	Standard.....1/2"
Speed (RPM) 5-Speed Soft Start:	Available.....1/4" & 3/8"
10,000 - 21,000	Net Weight.....15 lbs.

**FESTOOL OF 1400 EQ Plunge Router**

This router gives you more power in a light package, easy operation, smooth running, more routing depth, and the ultimate in dust extraction. The 1400 takes the medium-power router to a new level.

The 1400 Router gives you 2-1/4 HP in under 10 lbs., takes 1/2", 3/8", 1/4" or 8mm bits to handle almost any project.

Change bits quickly with the new ratcheting collet. The new chip catcher helps you work super clean for near-total dust extraction when used with a dust extractor. Category-leading 2-3/4" routing depth precise to 1/256" (1/10 mm).



574342

**OF 1400 Includes:**

- 8mm, 1/2", 1/4" collets
- Collet wrench
- Chip catcher
- Dust extraction hood
- Guide rods
- Standard U.S. guide bushing adaptor
- Plug-it cord
- Systainer

Power consumption.....	1400 watts/
	11.7 amps 120 V AC
Drive Shaft speed.....	10,000 - 22,500 rpm
Quick depth adjustment range...	2-3/4" (55mm)
Collet dia. range.....	1/4", 1/2", 8mm
Weight.....	9.9 lbs. (4.5 kg)

<u>Code</u>	<u>Price</u>
574342	\$ 555

**Guide Stop**

sold separately



Attaches 1400 router to guide rail system

<u>Code</u>	<u>Price</u>
492601	\$ 52

**FESTOOL OF 2200 EB Plunge Router**

Festool's most powerful router. Plunges easily into 8/4 hardwoods and makes a 1/2" groove in a single pass. 2200 watts of power. Exceptional maneuverability.

Also features four position depth stop, double column clamping, tool-less inserts, dust extraction and magnetic brake.



**OF 2200 EB Includes:**

- 1/2" collet
- Dust hood
- Systainer
- Chip catcher
- Collet wrench
- Standard U.S. guide bushing adapter

<u>Code</u>	<u>Price</u>
574354	\$ 900

Power consumption.....	2200 watts/ 15 amps 120 V AC
Drive Shaft speed.....	10,000 - 22,000 rpm
Quick depth adjustment range...	3-5/32" (80mm)
Collet dia. range.....	1/4", 1/2", 8mm
Weight.....	17.2 lbs.



**LOCK MORTISER**



**LOCK MORTISER**

Special Order

Model 513\*  
List \$ 2435



- 11 Amps, AC only
- 1-3/4 HP, 27,500 RPM
- Quick, accurate cutting of mortises for box locks
- Cuts mortises up to 7" long, 1-1/4" wide, 4-3/4" deep
- Automatically centers cutter on door edge
- Mounts to door in seconds
- Adjustable height rod for repetitive mortise cuts
- Includes height rod, 3/4" & 1" mortising bits, wrench set, and operating manual

**LOCK FACE TEMPLER**

Special Order

Model 517\*  
List \$ 525



Used to quickly rout lock faces on door after the mortise for the box lock itself has been completed. Automatically self-centering and self-beveling. Includes: Templet, 42024 Templet Guide and operating manual. Net Wt. 2-1/2 lbs. (Max Mortise 1-1/2" x 8-1/2")

**CORNER CHISEL**

Model 42234  
List \$ 33



Square the corners with Porter-Cable's No. 42234 Corner Chisel, and your door is ready to accept your lock face.

**ROUTING TEMPLATES**

**FESTOOL MULTI-ROUTING TEMPLATES**

The following templates work with these Festool Routers:

- 574339 (OF 1010 EQ),
- 574342 (OF 1400 EQ),
- 574354 (OF 2200 EB)

**MFS 400 Multi-Routing Template**

492610



Anodized aluminum profile with integral rule adjusts easily, accurate to 1/32". Rout circles, make precise inside or outside cuts, combine sets for unlimited size. Profiles are 7-7/8" by 3-1/8" and 15-3/4" by 3-1/8". Maximum interior dimension 4-11/16" by 12-9/16". Maximum circle diameter 34". Kit includes clamping flanges, tilt protector, circle routing insert, pivot point and adjustment tool.

Code	Description	Price
492610	Template MFS400	\$ 360

**MFS 700 Multi-Routing Template**

492611



Anodized aluminum profile with integral rule adjusts easily, accurate to 1/32". Rout circles, make precise inside or outside cuts, combine sets for unlimited size. Profiles are 15-3/4" by 3-1/8" and 27-1/2" by 3-1/8". Maximum interior dimension 12-9/16" by 24-7/16". Maximum circle diameter 51". Kit includes clamping flanges, tilt protector, circle routing insert, pivot point and adjustment tool.

Code	Description	Price
492611	Template MFS700	\$ 511



EDGE BANDER

FESTOOL

**Hand Held Edge Bander CONTURO KA 65**

With the new CONTURO Edge Bander, it's just as easy to apply edge banding on the job site as it is in the shop. Even if you have a large stationary edge banding machine, the CONTURO can complement your edge banding process by giving you a way to work with radii, circular pieces, bevels and small pieces.



#574609  
Hand Held  
Edgebander  
\$ 2800

Offers exceptional ergonomic design, including dual speeds, and a unique patented hot melt glue adhesive system. There's no risk of burns because the glue system is thermally isolated.

- Capable of edge banding curves, circles, convex and concave radii and inside corners
- Electronically controlled precision glue distribution system for maximum adhesion
- Compact, portable, ergonomic design for easy use and flexibility
- Optional table mounting for working with small work pieces

**Includes:**

- Natural EVA Adhesive, 4-Pack
- Support handle / guide table
- Systainer T-LOC SYS 4

**Specifications:**

Inner Radius Minimum of 2" (50mm)  
Max. Banding Height: 23/32" to 2-9/16" (18-65mm)  
Max. Banding Thickness: 1/32" to 1/8" (0.5-3.0mm)  
Weight: 17.4 lbs (7.9 kg.)



**Natural EVA Edge Banding Adhesive**  
48 pack / For above Edge Bander



#499812  
Natural Color

EVA edge banding adhesive. Available in natural (for natural wood edge banding), white (for most light colors of edge banding), brown and black (for most dark colors of edge banding).

Pack: 48 pcs.

Code	Color	List/bx
499812	Natural	\$ 125
499813	White	125
200059	Brown	125
200060	Black	125

**MFT/3 CONTURO Edge Bander Table Set**  
Combine with above Edge Bander

#500869 \$ 745

Conturo Edge Bander Table Set includes:

- Table insert
- Table adapter
- Guide plates
- Cross members

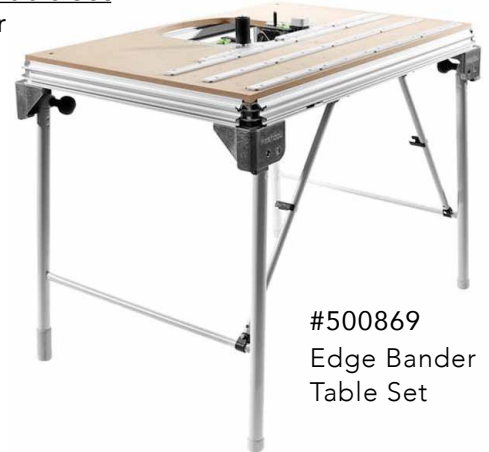

#500869  
Edge Bander  
Table Set

Combine the CONTURO Edge Bander with the Festool MFT/3 Work Table to process small work pieces and to edge band bevels. Edge bender can be quickly inserted and removed from the work table without any tools. The mounting bracket has preset detents for common angles.

Equipped with the Table Insert, Table Adapter, Guide Plates, and Cross Members, the MFT/3 CONTURO provides even more options for successful edge banding projects. Perfect for working with small pieces that would otherwise be difficult to work on with the CONTURO as a handheld machine.



**FESTOOL**

**DUST EXTRACTORS**

**Dust Extractor CT 36 HEPA**

For non-hazardous dusts

- **8.9 gal.** (33.7 L) bag capacity
- Larger wheels provide stability and ease of movement
- Locking brake on rear wheels means no accidental movement of the dust extractor
- Large flat area for tools or Systainer stacking
- Tool triggered or manual on-off switch with smooth start-up and shut-off delay
- Replaceable filter bag
- Stepless electronic suction control
- Integrated storage compartment
- Wet and dry extraction with no complicated conversion



583493

- Integrated cleaning device cleans the filter in the blink of an eye
- Blower port
- Standard antistatic equipment protects against electrostatic charging

**CT 36 E Includes:**

- HEPA filter
  - 1 fitted, Selfclean filter bag
  - 1 antistatic suction hose, 1-1/6" x 11.5 ft. (27mm x 3.5m)
  - 1 cord holder
  - Delivered in a box
- |  | <u>Code</u> | <u>Price</u> |
|--|-------------|--------------|
|  | 583493      | \$ 700       |

Container/Filter bag cap.....	9.5/8.9 gal.
Depth x Width x Height.....	24.8" x 14.4" x 23.4"
Weight.....	31.8 lbs.
Noise Level.....	62-71 dB (A)
Power Consumption.....	350-1200 watts/ 2.9-10 amps 120V AC
Max Suction Capacity.....	137 CFM
Max Vacuum.....	96" static water lift

**Dust Extractor CT 26 HEPA**

For non-hazardous dusts

- **6.3 gal.** (23.85 L) bag capacity
- Larger wheels provide stability and ease of movement
- Locking brake on rear wheels means no accidental movement of the dust extractor
- Large flat area for tools or Systainer stacking
- Tool triggered or manual on-off switch with smooth start-up and shut-off delay
- Replaceable filter bag
- Stepless electronic suction control
- Integrated storage compartment
- Wet and dry extraction with no complicated conversion



583492

- Integrated cleaning device cleans the filter in the blink of an eye
- Blower port
- Standard antistatic equipment protects against electrostatic charging

**CT 26 E Includes:**

- HEPA filter
  - 1 fitted, Selfclean filter bag
  - 1 antistatic suction hose, 1-1/16" x 11.5 ft. (27mm x 3.5m)
  - 1 cord holder
  - Delivered in a box
- |  | <u>Code</u> | <u>Price</u> |
|--|-------------|--------------|
|  | 583492      | \$ 650       |

Container/Filter bag cap.....	6.9/6.3 gal.
Depth x Width x Height.....	24.8" x 14.4" x 21.5"
Weight.....	28.7 lbs.
Noise Level.....	62-71 dB (A)
Power Consumption.....	350-1200 watts/ 2.9-10 amps 120V AC
Max Suction Capacity.....	137 CFM
Max Vacuum.....	96" static water lift

**Dust Extractor CT MIDI HEPA**

For non-hazardous dusts

- **3.3 gal.** (12.5 L) bag capacity
- Larger wheels provide stability and ease of movement
- Locking brake on rear wheels means no accidental movement of the dust extractor
- Large flat area for tools or Systainer stacking
- Tool triggered or manual on-off switch with smooth start-up and shut-off delay
- Replaceable filter bag
- Stepless electronic suction control
- Integrated storage compartment
- Wet and dry extraction with no complicated conversion



584165

- Integrated cleaning device cleans the filter in the blink of an eye
- Blower port
- Standard antistatic equipment protects against electrostatic charging

**CT MIDI Includes:**

- HEPA filter
  - 1 fitted, filter bag
  - 1 antistatic suction hose, 1-1/16" x 11.5 ft. (27mm x 3.5m)
  - 1 cord holder
  - Delivered in a box
- |  | <u>Code</u> | <u>Price</u> |
|--|-------------|--------------|
|  | 584165      | \$ 525       |

Container/Filter bag cap.....	3.96/3.3 gal.
Depth x Width x Height.....	17.5" x 13.5" x 18.5"
Weight.....	21.4 lbs.
Noise Level.....	62-72 dB (A)
Power Consumption.....	400-1200 watts/ 3.3-10 amps 120V AC
Max Suction Capacity.....	130 CFM
Max Vacuum.....	96" static water lift

**ACCESSORIES**

**FESTOOL**

**ACCESSORIES FOR CT SERIES DUST EXTRACTORS**

**Handle for CT22 and CT33 Dust Extractors**



- Improves mobility for the Festool CT 22 and CT 33 Dust Extractors
- Constructed from durable steel tubing with high impact plastic mounting brackets for a long life
- Mounts to the rear of the Dust Extractor.

<u>Code</u>	<u>Description</u>	<u>Price</u>
452921	Dust Extractor Handle	\$ 91

**Hose Garage For CT22 and CT33**

Provides a convenient way to keep your suction hose at hand and offers protections for your hose and cord during transport and storage



<u>Code</u>	<u>Description</u>	<u>Price</u>
494388	Hose Garage	\$ 62

**Replacement Filter Bags**

Contains 5 bags/box,  
Sold per box.

<u>Code</u>	<u>Description</u>	<u>Price/bx</u>
452970	For CT 22	\$ 38
452971	For CT 33	43



**Self-Cleaning Filter Bags**

Contains 5 bags/box,  
Sold per box.

<u>Code</u>	<u>Description</u>	<u>Price/bx</u>
498411	For CT MIDI	\$ 33
496187	For CT 26 E	38
496186	For CT 36 E	43
497539	For CT 48 E	49



**PLUG-IT REPLACEMENT POWER CORDS**

16 and 18 gauge

- 13 feet long
- Easily replace damaged or worn cords with the plug-it system
- By using a single cord:
  - save time switching between tools
  - minimize tangles and trip hazards
- Faster and easier to store and transport



<u>Code</u>	<u>Description</u>	<u>Price</u>
490656	16 gauge cord for use on TS55/TS75 Saws, OF1010/1400/MFK Routers	\$ 46
490649	18 gauge cord for use on Jigsaws, DF500 Domino, & Sanders	43

**HOSES FOR FESTOOL SANDERS**

Equipped with an integrated Plug-It Cord and sleeve, this tapered hose works well with the ETS EC sanders and others. The sleeve shrouds the hose to help prevent the rib of the hose from catching on materials which may damage the surface and also allows the hose to easily navigate over edges of work tables for easier work flow while sanding. Available in two lengths: 3.5 meter and 10 meter; the 3.5 meter is supplied in a Systainer SYS 3.



Hose w/ Sleeve  
10m (32.8')

<u>Code</u>	<u>Description</u>	<u>Price</u>
500276	Hose w/ sleeve, 3.5 m in a Systainer SYS 3	\$ 250
500940	Hose w/ sleeve, 10 m	375

**BOSCH JS470E JIGSAW**

Model JS470E

List \$ 303

**Features**

- 7-Amp motor plus speed control dial provides power and control for cutting through tough material
- Tool-less blade change system, fast insertion, blade ejection lever eliminates need to touch hot blade
- Four orbital-action settings provide different blade strokes for smooth to aggressive cuts
- Accelerator trigger controls operating speed
- Large, sturdy die-cast foot with steel insert and on-board bevel wrench, secure clamping system
- Precision-machined plunging system and low-vibration design enhances accuracy

Includes: Jig Saw, 1 no-mar overshoe, 1 anti-splinter insert, blade, bevel wrench and carrying case.

**Specifications:**

Dimensions: 15" depth, 13.5" width, 4.5" height

Weight: 10.38 lbs.

Amperage: 7

Bevel capacity: 45

Strokes per min: 3100

Length of stroke: 1"

Dust blower: Yes

Corded

UL Listed



JIGSAWS

FESTOOL

**PS 300 EQ Jigsaw**

**PSB 300 EQ Jigsaw**

Adjustable carbide-tipped jaws provide three-way blade guidance to ensure that the blade is perpendicular to the table at all times, even in curves. A splinter guard protects against chipping, leaving you with a clean, precise cut through the entire depth of the work piece, with little or no finishing.



**PS 300 EQ / 561443**

Barrel Grip fits your hand and provides a low center of gravity.

**PSB 300 EQ / 561455**

D-Handle features a fingertip trigger and smaller profile grip.

Power Consumption.....	720 watts / 6 amps 120 V AC
Stroke Rate (1").....	1000 - 2900 spm
Stroke Adjustment.....	4 Stages
Bevel Adjustment.....	0° - 45°
Cutting Depth, Wood.....	4-3/4" (120mm)
Cutting Depth, Non-Ferrous Metals.....	3/4" (20mm)
Cutting Depth, Steel.....	3/8" (10mm)
Weight.....	PS 300: 5.06 lbs. PSB 300: 5.29 lbs.

**Jigsaws Include:**

- T-Shank Jigsaw Blades for wood (2 pieces)
- Chip guard
- Splinter guard
- Plug-it cord
- In Systainer 1







Code	Jigsaw	Price
561443	PS 300 EQ	\$ 275
561455	PSB 300 EQ	275

**Accessories**

**Jigsaw Blades**

Cuts through Softwood/Hardwood, Melamine/Veneered Plywood, and chipboard.

5 blades/pack.

	Code	Blade Type	Cut Type	Material Thickness	Length	Tooth Type	Teeth per inch	Price/Pk
	486549	S 75/4 FS	Fine, perpendicular	Up to 2-1/8" (54mm)	3" (75mm)	 HCS	6-7	\$ 15
	499476	S75/4 FSG	Fast, perpendicular	Up to 2-1/8" (54mm)	3" (75mm)	 HCS	6-7	15
	486552	S105/4 FSG	Fast, perpendicular	Up to 3-3/8" (85mm)	4-1/8" (105mm)	 HCS	6-7	19

**Splinter Guard**

5 per pack.

Solid one-piece Splinterguard slides easily into place for a custom fit with any blade, virtually eliminating tearout and time-consuming rework. Fits all Festool Trion and Carvex Jigsaws.



<u>Code</u>	<u>Price</u>
490120	\$ 10

**SAW BLADES**



**LENOX TOP QUALITY JIG SAW BLADES**

Bi-Metal  
Jigsaw Blade



Lenox bi-metal Bosch-style jig saw blades out-perform and out-last anything else available today, including high-speed steel, conventional steel, and other bi-metal blades.

These blades possess far superior heat and wear resistance and produce a very smooth and clean finished cut. Each blade outlasts up to 5 ordinary blades, and is virtually unbreakable. Made in U.S.A.

The initial cost of the Lenox blades is more than carbon blades, but because they last so long, these blades are substantially more cost-effective than other blades.

Pack: 2 each per pack. Full packs only.

Code	Application	Teeth Per Inch	List Per Pack
BT410S	Wood, Nail-embedded	10	\$ 7.76
BT456S	Wood, Plastic	6	10.16
BT450S	Wood, Very Smooth	10	13.19
BT450SR	Wood, Down Cutting, Plastic Laminates, Reverse Tooth	10	12.74
BT320SC	Veneers, Laminates, Wood Fine Finishing, Contour/Scroll, Paneling, Formica	20	10.12
BT314S	Metal Over 1/4" Thick	14	7.60







Bulk	Description	List/Ctn
B450S-25	450S Bulk 25 ea/Ctn.	\$ 146.66

**Blade Comparison Chart**

Lenox #	Bosch =	Lenox	Bosch =
BT410S	T101C	BT450SR	T101BR
BT456S	T101D	BT320SC	T101AO
BT450S	T101B	BT314S	T101A

**BOSCH JIG SAW BLADES**

For Wood, Compositions, and Plastics: All 5 each/card.

Blade Reference	Part # / 5 blades/cd	Cutting Length	Teeth/Inch	List/cd
 T101B	T101B	2-1/2"	10	\$ 10.81
 T301CD	T301CD	3-1/4"	6	17.16
 T111C	T111C	2-1/2"	8	6.94
 T119BO	T119BO	1-7/8"	12	8.37
 T144D	T144D	2-1/2"	6	11.09
 T101BR	T101BR	4"	10	16.43
 T101D	T101D	4"	6	12.24

For Metal, Fiberglass, and Plastics: All 5 each/card.

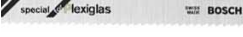
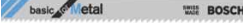
 T101A	T101A	2-1/2"	12	17.70
 T218A	T218A	3"	24	10.92

**BOSCH BULK JIG SAW BLADES**

Code	Description	List/pk
T101B-100	T101B-100 pack	\$ 163.48
T101BR-100	T101BR-100 pack	176.56
T101D-100	T101D-100 pack	163.48

**BOSCH T500 ASSORTMENT PACK**



Contains one each of the following jigsaw blades:

T101B, T144D, T119BD, T118A, T118B (T118A is 3" cutting length, 24 teeth/inch for cutting metal 1/16"-1/8". T118B is 3" cutting length, 14 teeth/inch for metal 1/8"-1/4")







Code	Description	List/Pk
T500	Asst. 5 blades	\$ 10.04



## JIG SAW BLADES

### LENOX RECIPROCATING BLADES

Lenox reciprocating blades have shatter-resistant teeth, and are highly wear-resistant. They cut easily through tough materials, including nail-embedded wood. Bi-metal construction, with high-speed alloy steel cutting edge (8% cobalt). Precision milled teeth have a hardness of RC 65-66. Angled tang. Cuts faster and lasts longer for increased productivity.

Recommended Use	Lenox #
Fast cutting, for rough work in wood 656R	 656R
Fast cutting, for rough work in wood 156R	 156R
Wood, plastic, cast aluminum, light non-ferrous metals, stainless steel 810R	 810R
Wood, plastic, cast aluminum, light non-ferrous metals, stainless steel 110R	 110R
Heavy-gauge metal 1/4-1/2", hard rubber, fiber & angle iron 614R	 614R
Heavy gauge metal 1/8"-1/4", conduit & tubing, opening wood crates 618R	 618R

Pack: 5 blades per pack.

Code	L x W x Thickness	Teeth/ Inch	List/pk
656R	6" x 3/4" x .050	6	\$ 28.18
156R	12" x 3/4" x .050	6	54.43
810R	8" x 3/4" x .050	10	34.42
110R	12" x 3/4" x .050	10/14	50.58
614R	6" x 3/4" x .035	14	23.92
618R	6" x 3/4" .035	18	24.46

### BOSCH "PROGRESSOR" JIG SAW BLADES

For use in all types of materials including metal and wood. The variable tooth pitch (small teeth near shank, larger teeth at the end of the blade), ensures fast cutting and long service life.

#### T123X



Best suited for metal. Also use on plastic up to 1-3/16" and wood up to 2-5/16" thick.

#### T345XF



A universal blade for use on non-ferrous metals, plastics and aluminum profiles up to 15/16", wood with nails up to 3-1/8" and steel.

#### T234X



For solid wood or laminated chipboard. Provides accurate and splinter free cuts with clean edges. Special tip for easy plunge cuts.

Pack: 5 each per card

Code	Application	Length	List/card
T123X	Metal	4-1/2"	\$ 12.89
T345XF	Universal	5"	20.00
T234X	Wood	4"	15.84



**FESTOOL**

**SAWS, GUIDE RAILS**

**TS 55 REQ Plunge Cut Track Saw**

Incredibly portable, precise and easy-to-use, the TS 55 REQ is at home in the shop and on the worksite. With micro-adjustable depth controls and a flat housing for cutting against flush surfaces it will give a perfect cut the first time, every time, with laser-straight, splinter free cuts.



**TS 55 REQ Saw**  
561556

**MFT/3  
Multifunction Table**  
495462

**Saw Includes:**

- 1 48-tooth carbide blade
- 55" (1400mm) guide rail
- Splinter guard
- Limit stop
- Plug-it cord
- In Systainer 4

Power consumption..... 1200 watts/ 10 amps 120 V AC  
Saw blade speed..... 2000 - 5200 rpm  
Saw blade diameter..... 6-1/4" (160mm)  
Bevel cuts..... -1° - 47° (positive stops at 0° & 45°)  
Cutting depth on guide rail..... 1-15/16" (50mm) straight down  
and 1-7/16" (37mm) at 45°  
Cutting depth w/o guide rail..... 2-1/8" (55mm) straight down  
Arbor size..... .787" (20mm)  
Weight..... 9.92 lbs. (4.5 kg)

Code	Price
561556 Saw	\$ 640
495462 Table	645

**TS 75 EQ Plunge Cut Track Saw**

Has a multitude of uses, from fine cabinetry to cutting spiral staircase steps; from truing rough lumber to cutting out window frames in renovation work. The TS 75 is a larger saw with more power and greater cutting depth than the TS 55.



**TS 75 EQ Saw**  
561438

**MFT/3  
Multifunction Table**  
495462

**Saw Includes:**

- 1 36-tooth carbide blade
- 75" (1900mm) guide rail
- Splinter guard
- Limit stop
- Plug-it cord
- In Systainer 4

Power consumption..... 1600 watts/ 13 amps 120 V AC  
Saw blade speed..... 1350 - 3550 rpm  
Saw blade diameter..... 8-1/4" (210mm)  
Bevel cuts..... 0° - 47° (positive stops at 0° & 45°)  
Cutting depth on guide rail..... 2-3/4" (70mm) straight down  
and 2-1/8" (55mm) at 45°  
Cutting depth w/o guide rail..... 2-15/16" (75mm) straight down  
Arbor size..... 1.101" (30mm)  
Weight..... 13.6 lbs. (6.2 kg)

Code	Price
561438 Saw	\$ 750
495462 Table	645

**The FS/2 Guide Rail**



Lay the guide rail on the workpiece and align the splinter guard flush with the scribe line. Place your Festool circular saw on the guide rail. The guide rib on the rail engages the guide slot on the tool, ensuring precision cutting every time. You save time and money by eliminating laborious measurements, rework and wasted material.

The Festool guide system is also an ideal solution for routing work at an angle or on the edge of workpieces. The guide cannot slip if secured with FSZ clamps. This prevents reworking and spoiled workpieces.

**FS/2 Guide Rails**



- Make precision cuts
- Hard-anodized surface
- Soft, non-slip coating
- Hard rubber splinter guard

Code	Description	Price
491498	FS 1400/2 - 55" Length (1400mm)	\$ 129
491503	FS 1900/2 - 75" Length (1900mm)	200
491937	FS 2700/2 - 106" Length (2700mm)	321
491501	FS 3000/2 - 118" Length (3000mm)	345

**Guide Rail Accessory Kit**



**Includes:**

- Angle unit
- Return/limit stop
- Extra splinterguard
- In Systainer 1
- Deflector
- 2 screw clamps
- 2 connectors

Code	Price
497657	\$ 217

Net Prices Shown

2040

**ACCESSORIES FOR PLUNGE SAWS**

**FESTOOL**

**Guide Rail Accessories cont.**

**Quick Clamp**



Easily locked and quickly released. For use with MF Table and Guide Rails. Fits seamlessly into the bottom T-slot of guide rails for limitless positioning and secure cutting.

Code	Ctn	Price
491594	1	\$ 39

**Splinterguard (Replacement)**



Adhesive backed Splinterguard to maintain splinter-free cut quality. Semi-transparent for better visibility of the cut line and is quick and easy to replace.

Code	Length	Price
495207	55"	\$ 21
495209	197"	41

**Connector**

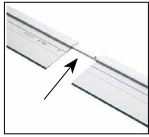

Connects two guide rails for long workpieces. Slide into the T-slot grooves in the rails. With 2 adjustable set screws per end for a secure connection. Sold per piece; 2 are needed.

Code	Ctn	Price
482107	1	\$ 18

**Splinterguard (For TS 75 EQ only)**



Achieve splinterfree cuts on both sides of the blade by using the off-cut side splinterguard in conjunction with the integrated guide rail splinterguard. For best results, replace when switching between different kerf blades.

Code	Pack	Price/pk
491473	5	\$ 22

**Multi-function Table MFT/3**

- Guide Rail System:  
For use with TS Plunge Saws and OF Routers
- Limitless versatility
- Portable
- Grid-hole pattern



Code	Dimensions	Price
495462	45-9/16" x 30-7/16"	\$ 645

**Saw Blades for TS Plunge Cut Track Saws**



ATB tooth



TC tooth



**Panther Saw Blade**

Fast-cutting rip blade with aggressive hook angle and deep gullets. Carbide-tipped ATB blade.

**TS 55 REQ**  
496305

**TS 75 EQ**  
495378



**Standard Saw Blade**

Coarse-cutting rip blade for use with building panels, wood and soft plastics. Carbide-tipped ATB blade.

**TS 75 EQ**  
495379



**Universal Saw Blade**

Clean-cutting general purpose blade for wood and soft plastics. Fine rip cut blade for glue-ready joints. Carbide-tipped ATB blade.

**TS 55 REQ**  
496304

**TS 75 EQ**  
495380

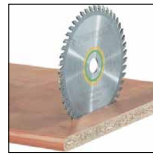

**Fine Tooth Saw Blade**

Cross-cut blade for smooth results in sheet goods, melamine, hard & soft woods. Carbide-tipped ATB blade.

**TS 55 REQ**  
495377

**TS 75 EQ**  
495381



**Solid Surface/Laminate Saw Blade**

Long-lasting, high-cut quality blade, ideal for laminate flooring and solid surface countertop materials. Carbide tipped TC blade.

**TS 55 REQ**  
496309

**TS 75 EQ**  
495382

**TS 55 REQ Saw blades**

Code	Dia.	Kerf	Bore	Hook Angle	Teeth	Price
496305	160	2.2	20	20°	12/ ATB	\$ 49
496304	160	2.2	20	15°	28/ ATB	54
495377	160	2.2	20	5°	48/ ATB	76
496309	160	2.2	20	4°	48/ TC	86

**TS 75 EQ Saw blades**

Code	Dia.	Kerf	Bore	Hook Angle	Teeth	Price
495378	210	2.6	30	28°	16/ ATB	\$ 76
495379	210	2.6	30	20°	18/ ATB	81
495380	210	2.4	30	15°	36/ ATB	86
495381	210	2.4	30	8°	52/ ATB	124
495382	210	2.4	30	4°	60/ TC	135

**SANDERS**



**SPEED BLOC®  
FINISHING SANDER**

Model 330PC  
List \$ 207.37

**Standard equipment includes:**  
Sander, Stikit®sheet, paper clamp tool and operating manual.  
Optional equipment: Felt rubbing pad #47699, sponge rubber pad #47696.



**Specifications:**

Double Insulated  
Power...120VAC, 25-60Hz/120VDC Motor Amps.....1.2  
Pad Speed (OPM).....14,000 Pad Size....4-1/8 x 4-1/2"  
Paper Size 4-1/2x5-1/2" (1.4 sheet) Net Weight.....4 lbs.

**BOSCH 3725DEVS RANDOM ORBIT SANDER  
WITH DUST CANISTER**

Model 3725DEVS  
List \$ 286



8-hole, 5" Hook & Loop

- Powerful 3.3 amp motor with variable-speed dial, (4,500-12,000 OPM) to match speed to workpiece and task
- Removable auxiliary handle for close-quarter work
- Microfilter dust canister collects up to 120% more dust than conventional dust bags
- Uses 8-hole, 5" hook and loop discs

**Specifications:**

Voltage..... 120V Orbit dia.....3/16"  
Disc size..... 5" Orbit rad.....3/32"  
No load OPM..... 4500-12000  
Eccentric offset.. 3/32"

**DYNABRADE RANDOM ORBIT AIR SANDER**



 **3/16"**  
(5 mm)  
Diameter Orbit

**For General Sanding**

 **3/32"**  
(2 mm)  
Diameter Orbit

**For Ultra-Fine Sanding**

Random circular motion produces superior finishes. Lightweight, low-profile sander. Highly dampened vibration gives smooth, comfortable sanding. Choice of 3/16" orbit or 3/32" orbit. Low air use. 90 PSI. 12,000 RPM. Approx. Wt: 1.40 lbs on 5", 1.50 lbs on 6" Horse power: .25

Includes low-profile, premium urethane, weight-mated, non-vac pad (PN56106). Non-vac with a small ergonomic grip.

Code	Dia./Orbit	List
59020	5" / 3/16"	\$ 266.90
59025	6" / 3/16"	266.90
59035	5" / 3/32"	266.90

**5" RANDOM ORBIT SANDER  
WITH DUST PICKUP**

8-hole Hook & Loop Pad

Model 382  
List \$ 108



8-hole, 5" Hook & Loop

- Top cap design allows users to service and clean out the unit without complete disassembly
- Improved ergonomics allow for comfortable body & top gripping
- Amps: 1.9, 12,000 OPM
- Rubber grip dampens vibration
- 8-hole hook & loop pad. Accepts standard paper.
- Dust canister exceeds durability of cloth dust bags
- Dual dust ports accept 1" and 1-1/2" vacuum hoses to maximize dust pick up
- Standard Equipment: Sander, and operating manual

**BELT SANDERS**

**3 X 24" BELT SANDER WITH DUST PICK-UP**

Model 360PC  
List \$ 585.52



- Top quality production sander/gear and belt drive.
- Precision, long wearing ball and needle bearing construction.
- Perfect balance design.
- Extra-large dust bag swivels for better sanding in tight areas.
- Powerful vacuum dust removal system.
- **Standard equipment includes:** Sander, abrasive belt, #39334 dust bag assembly and operating manual.

**Specifications:**

Power... 120VAC, 25-60Hz/120VDC	Belt Size.....3 x 24"
Motor Amps..... 12.0	Length.....14"
No Load Speed (SFPM)..... 1,500	Net Wt.....14-1/2 lbs

**3 X 24" BELT SANDER**

Model 361PC  
List \$ 556.99



- Top-quality production sander/gear belt drive.
- Precision, long wearing ball and needle bearing construction.
- Perfect balance design.
- **Standard equipment includes:** Sander, abrasive belt and operating manual.

**Specifications:**

Power...120VAC, 25-60Hz/120VDC	Belt Size.....3 x 24"
Motor Amps.....12.0	Length.....14"
No Load Speed (SFPM).....1,550	Net Weight....13-3/4 lbs

**4 X 24" BELT SANDER WITH DUST PICK-UP**

Model 362PC  
List \$ 555.67



- Top quality production sander/gear and belt drive.
- Precision, long wearing ball and needle bearing construction.
- Perfect balance design.
- Extra-large dust bag swivels for better sanding in tight areas.
- Powerful vacuum dust removal system.
- **Standard equipment includes:** Sander, abrasive belt, #39334 dust bag assembly and operating manual.

**Specifications:**

Power... 120VAC, 25-60Hz/120VDC	Belt Size.....4 x 24"
Motor Amps..... 12.0	Length.....14"
No Load Speed (SFPM)..... 1,500	Net Weight...15-1/2 lbs

**GRAPHITE COATED CANVAS**

Graphite has long proven the most effective dry lubricant available for use in back of sanding belts to reduce heat and friction, increase speed and provide longer abrasive belt wear. Recommended by most belt-sander manufacturers.



Available in 10' lengths only.

<u>Code</u>	<u>Width x Length</u>	<u>List/ea</u>
GC4-1	4" x 10'	\$ 27.32
GC6-1	6" x 10'	40.46
GC8-1	8" x 10'	57.36

**FESTOOL**

**SANDERS**

**DTS 400 EQ Orbital Sander**

A great all-round sander, the DTS 400 is ideal for working on vertical and overhead surfaces because of its compact design and weight of only 2.4 lbs. The electronics improve working results and the vibration stop makes your work less tiring.



567871

**DTS 400 EQ Includes:**

- StickFix® sanding pad 4" x 6" (100 x 150mm)
- Plug-it Power cord
- Filter bag and holder
- In Systainer 1

Note: Pads not interchangeable with RTS 400 EQ

	<u>Code</u>	<u>Price</u>
Power consumption.....200 watts/ 1.67 amps 120 V AC	567871	\$ 255
Pad size.....4" x 6" (100 x 150mm)		
Speed.....6000 - 14000 opm		
Sanding stroke.....5/64" (2mm)		
Weight.....2.4 lbs. (1.1 kg)		

**RTS 400 EQ Orbital Sander**

A sander well suited for a wide range of applications, the RTS 400 is ideal for working on vertical and overhead surfaces because of its compact design and weight of only 2.4 lbs. The electronics improve working results and Vibration Stop balancing reduces fatigue during prolonged use.



567863

**RTS 400 EQ Includes:**

- StickFix® sanding pad 3-5/32" x 5-1/4" (80 x 133mm)
- Plug-it Power cord
- Filter bag and holder
- In Systainer 1

Note: Pads not interchangeable with DTS 400 EQ

	<u>Code</u>	<u>Price</u>
Power consumption.....200 watts/ 1.67 amps 120 V AC	567863	\$ 255
Pad size.....3-5/32" x 5-1/4" (80mm x 133mm)		
Speed.....6000 - 14000 opm		
Sanding stroke.....5/64" (2mm)		
Weight.....2.4 lbs. (1.1 kg)		

**RS 2 E Orbital Sander**

The large 4-1/2" x 9" sanding surface makes the RS 2 E an efficient choice for fine sanding large surfaces. Typical applications include intermediate sanding of varnished doors, leveling large surfaces, and sanding narrow pieces without rounding over edges. An additional ergonomic handgrip permits guidance with little force to avoid fatigue during long sessions.



567696

**RS 2 E Includes:**

- StickFix® sanding pad 4-1/2" x 9" (115 x 228mm)
- Plug-it Power cord
- Filter bag and holder
- In Systainer 1

	<u>Code</u>	<u>Price</u>
Power consumption.....330 watts/ 2.75 amps 120 V AC	567696	\$ 410
Pad size.....4-1/2" x 9" (115mm x 228mm)		
Speed.....4000 - 10000 opm		
Sanding stroke.....3/32" (2mm)		
Weight.....5.5 lbs. (2.5 kg)		





**SANDERS**

**FESTOOL**

**ROTEX RO 125 FEQ Multi-Mode Sander**

The RO 125 puts dual-mode, triple-function performance into a comfortable 4.4 lbs. This 5" sander does coarse sanding, fine sanding and polishing. Perfect for woodworkers, painters, solid surface fabricators and anyone who needs to sand in a variety of places and positions. Near-total dust extraction, exceptional ergonomics, and many advanced features.



571782

**RO 125 FEQ Includes:**

- StickFix® sanding pad 5" dia (125mm)
- Edge protector
- Plug-it cable
- Systainer

Power consumption.....	500 watts/ 4.2 amps 120 V AC
Pad diameter.....	5" (125mm)
Speed Eccentric motion.....	3000 - 6000 opm
Speed Rotary motion.....	300 - 600 rpm
Sanding stroke.....	9/64" (3.6mm)
Weight.....	4.4 lbs. (2 kg)

<u>Code</u>	<u>Price</u>
571782	\$ 480

**ROTEX RO 150 FEQ Multi-Mode Sander**

The RO 150 changes effortlessly from coarse sanding, to fine sanding, to polishing. Changing sanding pads is easy and requires no extra tools. 720 watts of power. The 5 lb. frame has minimal vibration and superior ergonomic design making it easy to work with. The gear box is completely enclosed and impervious to dust.



571810

**RO 150 FEQ Includes:**

- StickFix® sanding pad 6" dia (150mm)
- 1 abrasive sheet
- Edge protector
- Removable dust channel
- Auxillary side handle
- Plug-it cable
- Systainer

Power consumption.....	720 watts/ 6 amps 120 V AC
Pad diameter.....	6" (150mm)
Speed Eccentric motion.....	3300 - 6800 opm
Speed Rotary motion.....	320 - 660 rpm
Sanding stroke.....	3/16" (5mm)
Weight.....	5 lbs. (2.3 kg)

<u>Code</u>	<u>Price</u>
571810	\$ 585

**ETS 125 EQ Random Orbital Sander**

The ergonomic ETS 125 has a 5/64" sanding stroke and is an ideal one-handed machine for maximum surface quality when finishing or pre-sanding. Weighing only 2.4 lbs., it is perfect for vertical surfaces and overhead work. Also features sanding pad brake and Vibration Stop balancing.



**ETS 125 EQ Includes:**

- StickFix® sanding pad 5" dia (125mm)
- Filter bag w/ holder
- Plug-it cable
- Systainer

<u>Code</u>	<u>Price</u>
571817	\$ 195

Power consumption.....	200 watts/ 1.67 amps 120 V AC
Pad diameter.....	5" (125mm)
Speed.....	6000 - 14000 opm
Sanding Stroke.....	5/64" (2.0mm)
Weight.....	2.4 lbs. (1.1 kg)

**Random Orbital Sanders**

**ETS 150/3 EQ and ETS 150/5 EQ**

Two top-of-class, lightweight eccentric sanders in the ETS series: the ETS 150/3 is for fine sanding and extra-fine sanding, producing an excellent surface finish with a short 1/8" sanding stroke. The ETS 150/5, with a 3/16" stroke, is for more aggressive sanding or intermediate varnish sanding. Its maneuverability is a product of superior ergonomics and low weight. The balance of each tool is calibrated to its stroke, delivering smooth, low vibration operation.



**ETS 150/3 EQ & ETS 150/5 EQ Include:**

- StickFix® sanding pad 6" dia (150mm)
- Filter bag w/ holder
- Plug-it cable
- Systainer

Power consumption.....	310 watts/ 2.6 amps 120 V AC
Pad diameter.....	6" (150mm)
Speed.....	6000 - 10500 opm
Sanding Stroke (150/3).....	1/8" (3.0mm)
Sanding Stroke (150/5).....	3/16" (5.0mm)
Weight.....	2.4 lbs. (1.1 kg)

<u>Code</u>	<u>Price</u>
ETS 150/3	\$ 360
571903	
ETS 150/5	360
571916	

**FESTOOL**

**SANDERS**

**ETS EC 125 EQ**

**Brushless Sander**

Equipped with the EC-TEC® Brushless Motor, these low-profile, long-life, and low-vibration sanders can run all day with multiple shifts. Offering a fine 3 mm stroke, this sander provides the performance of an air sander without the expense and bulk of an air system. Equipped with Multi-Jetstream dust extraction, extraction connection signal, electronic active vibration stop, carbide-tipped sanding brakes and more.



571897

**ETS EC 125 EQ Includes:**

- StickFix® sanding pad 5" dia (125mm)
- Plug-it cable
- Systainer SYS 2 TL

Power consumption.....	400 watts/ 3.3 amps 120 V AC		
Pad diameter.....	5" (125mm)		
Speed.....	6000 - 10000 RPM	<u>Code</u>	<u>Price</u>
Sanding stroke.....	1/8" (3.0mm)	571897	\$ 385
Weight.....	2.6 lbs. (1.2 kg)		

**ETS EC 150/3 EQ**

**Brushless Sander**

Equipped with the EC-TEC® Brushless Motor, these low-profile, long-life, and low-vibration sanders can run all day with multiple shifts. Available in a fine 3 mm stroke or a broader 5 mm stroke, these sanders offer the performance of an air sander without the expense and bulk of an air system. Equipped with Multi-Jetstream dust extraction, extraction connection signal, electronic active vibration stop, carbide-tipped sanding brakes and more.



571880

**ETS EC 150/3 EQ Includes:**

- StickFix® sanding pad 6" dia (125mm)
- Plug-it cable
- Systainer SYS 2 TL

Power consumption.....	400 watts/ 3.3 amps 120 V AC		
Pad diameter.....	6" (150mm)		
Speed.....	6000 - 10000 RPM	<u>Code</u>	<u>Price</u>
Sanding stroke.....	1/8" (3.0mm)	571880	\$ 485
Weight.....	2.6 lbs. (1.2 kg)		

**ETS EC 150/5 EQ**

**Brushless Sander**

Equipped with the EC-TEC® Brushless Motor, these low-profile, long-life, and low-vibration sanders can run all day with multiple shifts. Available in a fine 3 mm stroke or a broader 5 mm stroke, these sanders offer the performance of an air sander without the expense and bulk of an air system. Equipped with Multi-Jetstream dust extraction, extraction connection signal, electronic active vibration stop, carbide-tipped sanding brakes and more.



571892

**ETS EC 150/5 EQ Includes:**

- StickFix® sanding pad 6" dia (125mm)
- Plug-it cable
- Systainer SYS 2 TL

Power consumption.....	400 watts/ 3.3 amps 120 V AC		
Pad diameter.....	6" (150mm)		
Speed.....	6000 - 10000 RPM	<u>Code</u>	<u>Price</u>
Sanding stroke.....	3/16" (5.0mm)	571892	\$ 485
Weight.....	2.6 lbs. (1.2 kg)		



**FESTOOL SANDPAPER**

For Models: RO 125 FEQ  
ETS 125 EQ



StickFix® abrasive sheets



**Cristal** For wood, paint, plastics and fillers. Dia: 5"

Code	Grit	Ctn	Price/ctn
494035	P100	100 ea	\$ 45.99
494036	P120	100	45.99

**Rubin2** For bare wood. Dia: 5"



Code	Grit	Ctn	Price/ctn
499094	P60	50 ea	\$ 29.00
499095	P80	50	29.00
499096	P100	50	29.00
499097	P120	50	29.00
499098	P150	50	29.00
499099	P180	50	29.00
499100	P220	50	29.00

For Models: RO 150 FEQ  
ETS 150/3 EQ, 150/5 EQ



StickFix® abrasive sheets



**Rubin2** For bare wood. Dia: 6"

Code	Grit	Ctn	Price/ctn
499118	P60	50	\$ 35.00
499119	P80	50	35.00
499120	P100	50	35.00
499121	P120	50	35.00
499122	P150	50	35.00
499123	P180	50	35.00
499124	P220	50	35.00

**Brilliant2** For bare wood. Dia: 6"



Code	Grit	Ctn	Price/ctn
496587	P80	50 ea	\$ 39.00
496588	P100	100	60.00
496589	P120	100	60.00
496590	P150	100	60.00
496591	P180	100	60.00
496592	P220	100	60.00
496594	P320	100	60.00

For Model: DTS 400 EQ



StickFix® abrasive sheets



**Brilliant2** For paints and varnishes, fine sanding on bare wood. Size: 3-11/16" (100 x 150mm)

Code	Grit	Ctn	Price/ctn
492795	P80	50 ea	\$ 29.00
492796	P100	100	41.00
492797	P120	100	41.00
492798	P150	100	41.00
492799	P180	100	41.00
492800	P220	100	41.00
492801	P240	100	41.00
492802	P320	100	41.00
492803	P400	100	41.00

**Rubin2** For bare wood. Size: 3-11/16" (100 x 150mm)



499135	P80	50 ea	\$ 25.00
499136	P100	50	24.00
499137	P120	50	25.00
499138	P150	50	24.00
499139	P180	50	25.00

**Granat** For finished and bare wood. Size: 3-11/16" (100 x 150mm)



497140	P180	100 ea	\$ 46.00
497141	P220	100	46.00
497143	P320	100	46.00

For Model: RS 2 E



StickFix® abrasive sheets



**Rubin2** For bare wood. Dia: 6" Size: 4-1/2" x 9"

Code	Grit	Ctn	Price/ctn
499031	P60	50	\$ 31.00
499032	P80	50	31.00
499033	P100	50	31.00
499034	P120	50	31.00
499035	P150	50	31.00
499036	P180	50	31.00
499037	P220	50	31.00

**FESTOOL**

**For Models: LS 130 EQ  
RTS 400 EQ**



**StickFix® abrasive sheets**



**Cristal** For wood, paint, plastics and fillers.  
Size: 3-5/32" x 5-1/4"

Code	Grit	Ctn	Price/ctn
494057	P40	50 ea	\$ 21.00
494058	P60	50	21.00
494059	P80	50	21.00
494060	P100	50	21.00
494061	P120	50	21.00

**Rubin2** For bare wood.  
Size: 3-5/32" x 5-1/4"



499047	P60	50 ea	22.00
499048	P80	50	22.00
499049	P100	50	22.00
499050	P120	50	22.00
499051	P150	50	22.00
499052	P180	50	22.00
499053	P220	50	22.00

**SIA 9-Hole HOOK & LOOP DISCS**

For Festool Sanders



- 5" or 6" 9-hole discs
- Aluminum oxide grit
- B-weight paper
- Ideal for manual use thanks to high flexibility
- Ideal for sanding large areas

Pack: 100 discs per box.

Code	Size	Grit	List/bx
4554.0675.0080	5"	80	\$ 67.28
3547.7578.100	5"	100	62.58
3547.7578.120	5"	120	67.03
3547.7578.150	5"	150	65.72
3547.7578.180	5"	180	65.72
3547.7578.220	5"	220	65.72
3365.8780.80	6"	80	97.82
3365.8780.100	6"	100	93.66
3365.8780.120	6"	120	93.66
3365.8780.150	6"	150	90.06
3365.8780.180	6"	180	90.06
3365.8780.220	6"	220	93.66

**SOFT SANDER BACKING PADS**

For Festool Sanders



StickFix Longlife 5" Pad  
492280  
For ETS 125 EQ  
Random Orbital Sander



Fusion Tec 6" Soft Pad  
498987  
For ETS 150/3, ETS150/5 EQ  
Random Orbital Sanders



StickFix 5" Soft Pad  
492125  
For Rotex RO 125 FEQ  
Multi-Mode Sander



StickFix 6" SuperSoft Pad  
496144  
For Rotex RO 150 FEQ  
Multi-Mode Sander



StickFix 6" Soft Pad  
496147  
For Rotex RO 150 FEQ  
Multi-Mode Sander

High-Temp resistant for heavy-duty applications.  
9-hole.

Code	Dia.	Sander	Net/ea
492280	5"	ETS 125 EQ	\$ 38.00
498987	6"	ETS 150/3 EQ, ETS150/5 EQ	46.00
492125	5"	RO 125 FEQ	36.00
496144	6"	RO 150 FEQ	46.00
496147	6"	RO 150 FEQ	46.00



**FESTOOL**

**BACKING PADS**

For Festool ETS EC Sanders

The ETS EC 125 requires a different pad than the ETS 125. Below backing pads have a central fastener to affix to the sander, but still use the same abrasives that the ETS 125 uses. The ETS EC 150 sanders utilize the same sanding pads as the ETS 150 sanders.



5" Hard Sander Backing Pad  
492284  
For ETS EC 125  
Brushless Sander



5" Soft Longlife Sander  
Backing Pad - 492286  
For ETS EC 125  
Brushless Sander



5" Super Soft Sander  
Backing Pad - 492288  
For ETS EC 125  
Brushless Sander

<u>Code</u>	<u>Dia.</u>	<u>Sander</u>	<u>Net/ea</u>
492284	5"	ETS EC 125	\$ 42
492286	5"	ETS EC 125	42
492288	5"	ETS EC 125	42



**MLCS**

**ROUTER BITS**

**ROUTER BIT SET - 30 PC MLCS**

Outstanding value. An MLCS bit rated 6th out of the 17 brands tested in Fine Woodworking (8/99).



Each set includes 30 carbide tipped, high quality router bits with wood storage box. Each set includes:

- 3 Cove (1/4", 3/8", 1/2")
- 2 Flush Trim (3/8", 1/2")
- 3 Dovetail (14° 1/2", 5/8", 9° 3/8")
- 1 45° Chamfer, 2 Roman Ogee (5/32", 1/4")
- 6 Round Over (1/8", 3/16", 1/4", 5/16", 3/8", 1/2")
- 5 Straight (1/4", 5/16", 3/8", 1/2", 3/4")
- 1 Rabbeting (3/8"), 3 Round Nose (1/4", 3/8", 1/2")
- 1 Bevel (25°), 1 Slot Cutter (1/4")
- 1 V-Groove (1/2"), 1 Panel Pilot (3/8")
- 1 Allen Wrench and 1 bearing to convert Round Over bit into Beading bit, and wood storage box. Available in 1/4" and 1/2" shank.

<u>Code</u>	<u>Description</u>	<u>List</u>
8369	30 Bit Set, 1/2 Shank	\$ 184.03
6069	30 Bit Set, 1/4 Shank	189.64

**FLUSH TRIM ROUTER BITS - MLCS**

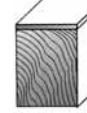
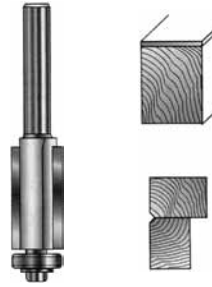

2 flute, carbide tipped flush trim bits with totally enclosed ball bearing guides. For use in trimming laminates and pattern routing.



V-notch bits make a "V" where two pieces join together, hiding a less than perfect joint.

<u>Code</u>	<u>Bit</u>	<u>Large Dia.</u>	<u>Cutting Length</u>	<u>Shank Size</u>	<u>List</u>
5500	Flush	3/8"	1/2"	1/4"	\$ 15.20
5501	Flush	3/8"	1"	1/4"	15.20
5503	Flush	1/2"	1"	1/4"	15.20

**EURO-TRIMMER LAMINATE TRIMMING BIT**

Revolutionary Design



Square Teflon Bearing

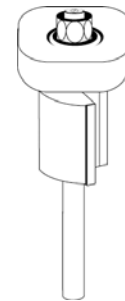

ET-34

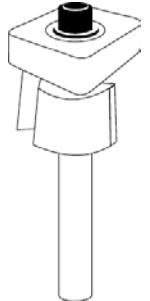

ET-12

The Euro-Trimmer with square Teflon bearing will not scratch laminates, and glue will not stick to the bearing (other designs clog with contact adhesive).

The 3/4" diameter cutter with a 2° bevel provides very smooth cuts. When using the bit there is no need to lubricate surface. Do the same work in less time.

**Specifications:** Cutter: Tungsten Carbide  
Bearing: Black Teflon

<u>Code</u>	<u>Description</u>	<u>List</u>
ET-12	Size: 1/2" Euro-Trimmer with 1/4" Shank For hand held routers	\$ 43.06
ET-34	Size: 3/4" Euro-Trimmer with 1/4" Shank For larger routers and router tables	46.87
ET12B	Teflon bearing for ET-12	13.17
ET34B	Teflon bearing for ET-34	13.17



**ROUTER BITS**

**CMT**

**CMT FLUSH & V-GROOVE BITS**

Carbide Tipped with ball-bearing guide.

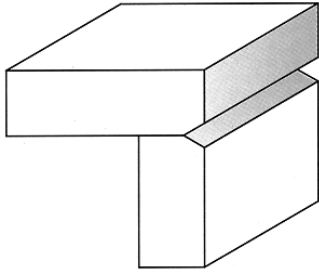

<u>Code</u>	<u>Cut Shank</u>	<u>Cut Dia.</u>	<u>Ovall Length</u>	<u>Length</u>	<u>List</u>
853.001.11	1/4"	1/2"	1"	3/4"	\$ 33.72
853.501.11	1/2"	1/2"	1"	3/4"	37.50

**CMT FLUSH TRIM BITS**

Carbide Tipped with ball-bearing guides.

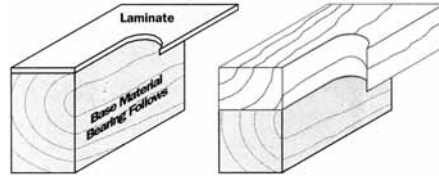

<u>Code</u>	<u>Shank</u>	<u>Cut Dia.</u>	<u>Cut Length</u>	<u>Bearing Dia.</u>	<u>List</u>
806.096.11	1/4"	3/8"	1/2"	3/8"	\$ 22.11
806.128.11	1/4"	1/2"	1/2"	1/2"	21.73
806.127.11	1/4"	1/2"	1"	1/2"	21.69
806.627.11	1/2"	1/2"	1"	1/2"	24.40

**CMT SUPER-DUTY FLUSH TRIM BITS**

Carbide Tipped with ball-bearing guides.

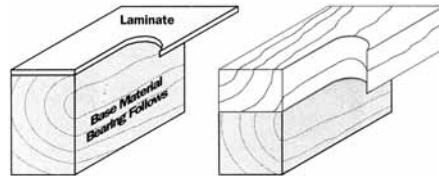

New super duty bits represent the finest of the CMT flush trim bits with ball-bearing guides. Negative shear angle cutting edge and 3/4" cutting diameter. A superior finish with absolute minimal chipping.

<u>Code</u>	<u>Shank</u>	<u>Cut Dia.</u>	<u>Cut Length</u>	<u>List</u>
806.191.11	1/4"	3/4"	1"	\$ 34.13
806.691.11	1/2"	3/4"	1"	37.31
806.690.11	1/2"	3/4"	2"	46.20

**CMT**

**ROUTER BITS**

**CMT RABBETING BITS**

Carbide tipped.  
With ball-bearing guides

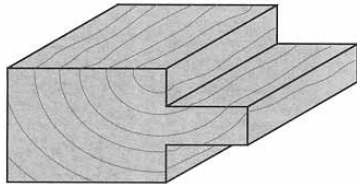

Carbide faced rabbeting bits are fast and accurate. You can quickly produce 3/8" inset doors and drawer fronts, make strong rabbeted joints, mill perfect tongue and groove joints, etc.

Code	Shank	Cut Dia.	Cut Length	Cut Depth	Bearing Dia.	List
835.317.11	1/4"	1-1/4"	1/2"	3/8"	1/2"	\$ 34.76
835.817.11	1/2"	1-1/4"	1/2"	3/8"	1/2"	36.96

**CMT ROUNDOVER BITS**

Carbide Tipped. With ball-bearing guides

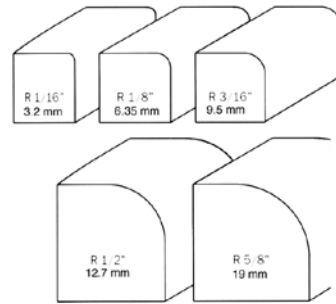

Code	Shank	Cutting Radius	Ovall Dia.	Cut Length	Bearing Dia.	List
838.190.11	1/4"	1/8"	3/4"	1/2"	1/2"	\$ 35.49
838.254.11	1/4"	1/4"	1"	1/2"	1/2"	40.35
838.754.11	1/2"	1/4"	1"	1/2"	1/2"	41.71
838.317.11	1/4"	3/8"	1-1/4"	9/16"	1/2"	41.77
838.817.11	1/2"	3/8"	1-1/4"	9/16"	1/2"	41.70
838.380.11	1/4"	1/2"	1-1/2"	3/4"	1/2"	44.59
838.990.11	1/2"	3/4"	2"	1"	1/2"	74.17

**CMT RABBETING SETS**

Carbide Tipped

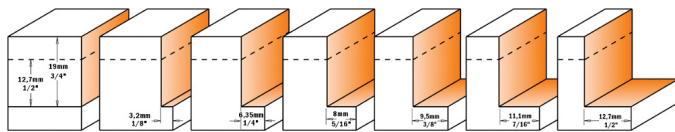

CMT rabbeting sets allow you to make a limitless number of cuts by adjusting the cutting height on your router and changing the bearing on the bit. Each set comes complete with one rabbeting bit and six interchangeable ball-bearing guides.

Code	Shank	Cut Dia.	Cut Length	Cutting Depth	List/set
835.001.11	1/4"	1-3/8"	1/2"	1/8" to 1/2"	\$ 70.62
835.501.11	1/2"	1-3/8"	1/2"	1/8" to 1/2"	66.22

**CMT BEARINGS**

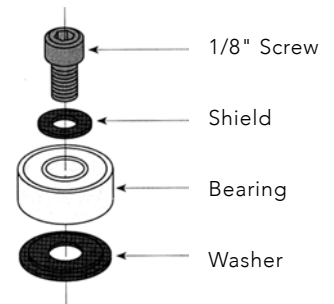

BE SURE to keep the black bearing washer right side up to correspond with the bearing rotation when re-assembling the bearing.

Code	Outside Dia.	Inside Dia.	List
791.002.00	3/8"	3/16"	\$ 5.57
791.003.00	1/2"	3/16"	4.51
791.004.00	3/4"	1/4"	5.35



ROUTER BITS

CMT

CMT STRAIGHT BITS

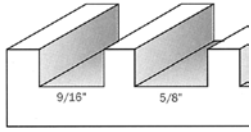

812  
Long Series



811  
Short Series

Long Series - 812 Carbide Tipped

Code	Shank	Cut Dia.	Cut Length	Overall Length	List
812.595.11	1/2"	3/8"	1-1/4"	2-7/8"	\$ 25.24
812.127.11	1/4"	1/2"	1-1/4"	2-3/4"	23.15
812.690.11	1/2"	3/4"	1-1/2"	3-1/4"	30.70

Short Series - 811 Carbide Tipped

811.127.11	1/4"	1/2"	3/4"	2-1/4"	\$ 21.53
------------	------	------	------	--------	----------

CMT PATTERN BITS - Carbide Tipped

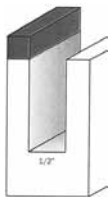

812B  
Long Series



811B  
Short Series



Code	Shank	Cut Dia.	Cut Length	Overall Length	List
812.127.11B	1/4"	1/2"	1-1/4"	2-3/4"	\$ 40.63
811.127.11B	1/4"	1/2"	3/4"	2-1/4"	31.40

Bearing Dia: 1/2"

CMT MORTISING BITS - Carbide Tipped

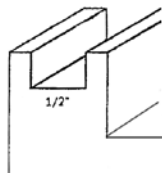
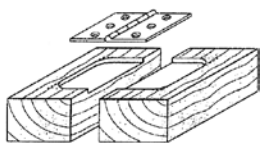

Code	Shank	Cut Dia.	Cut Length	List
801.128.11	1/4"	1/2"	5/16"	\$ 23.68

CMT CARBIDE TIPPED BORING BITS

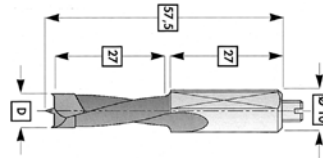

5mm, 8mm

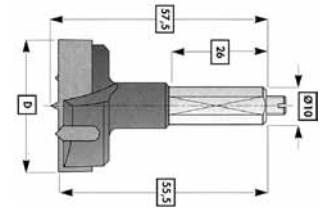

35mm, 40mm

CMT carbide tipped boring bits have "fatigue proof" Swiss steel body, micrograin carbide tips, bake-on PTFE non-stick coating and superb workmanship. Capable of high feed rates in CNC and multi-spindle boring machines. Made in Italy. (Not for use with 3-jawed chucks.)

Bit Dia.	Right Hand	Left Hand	List
5mm	310.050.11	310.050.12	\$ 14.52
8mm	310.080.11	310.080.12	20.91
35mm	317.350.11	--	38.32
40mm	317.400.11	--	63.55

CMT BABY LOCK MITER

Cut Angle 45°

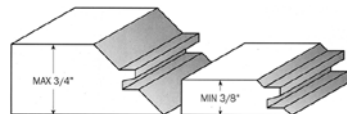

Lock miter bit is ideal for milling miter joints in 3/4" stock. The quick and easy way to accurately create boxes, stretcher bars, frames and any assortment of right angle or parallel joint projects.

Code	Cut Dia.	Cut Length	Max joint thickness	Shank	List
855.504.11	2"	7/8"	3/4"	1/2"	\$ 119.99

**BOSCH**

**STRAIGHT BITS**

**STRAIGHT BITS** Solid Carbide, Double Flute

Micrograin bits provide exceptional smoothness of cut and balanced cutting with minimal vibration. Positive hook angles cut efficiently, and specially designed tips allow for fast plunge cutting. Strong webbing and heavy cutter backing provide superior bit life.

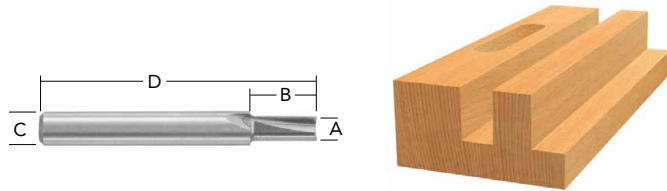

Bit No.	A Overall Dia.	B Cutting Edge Lgth.	C Shank Dia.	D Overall Length	List
85213M	1/8	7/16	1/4	2	\$ 24.07
85214M	3/16	7/16	1/4	2	21.94

**STRAIGHT BITS** High Speed Steel, Double Flute

Provide smooth and balanced cutting with minimal vibration. Positive hook angles cut efficiently while specially designed tips provide fast plunge cutting. Strong webbing and heavy cutter backing extend bit life.

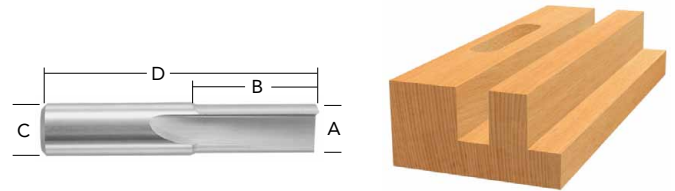

Bit No.	A Overall Dia.	B Cutting Edge Lgth.	C Shank Dia.	D Overall Length	List
85096	1/4	3/4	1/4	2	\$ 9.59
85180	1/4	1-1/8	1/4	2-3/8	10.04
85100	1/2	7/8	1/4	2-1/4	12.14
85102	5/8	5/8	1/4	1-5/8	13.37

**STRAIGHT BITS** Carbide Tipped, Double Flute

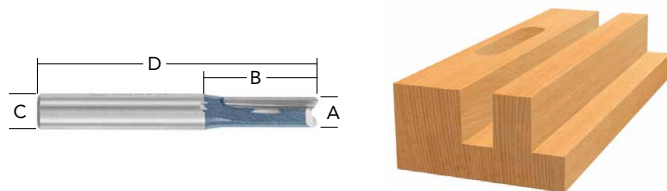

Bit No.	A Overall Dia.	B Cutting Edge Lgth.	C Shank Dia.	D Overall Length	List
85221M	1/4	5/8	1/4	2	\$ 21.99
85250M	1/4	7/8	1/4	2-1/8	24.24
85223M	9/32	1	1/4	2-1/4	26.59
85224M	5/16	1	1/4	2-1/4	23.73
85225M	3/8	1	1/4	2-1/4	23.49
85226M	7/16	1	1/4	2-1/8	26.40
85227M	1/2	1	1/4	2-1/4	25.43
85242M	1/2	1-1/2	1/2	3-1/8	27.42
85251M	1/2	2	1/2	4-1/4	34.61
85230M	5/8	3/4	1/4	2	25.94

**STRAIGHT BITS** High Speed Steel, Single Flute

Designed for roughing operations where high production feed rates are essential. Optimum chip clearance. Specially designed tip for fast plunge cutting.

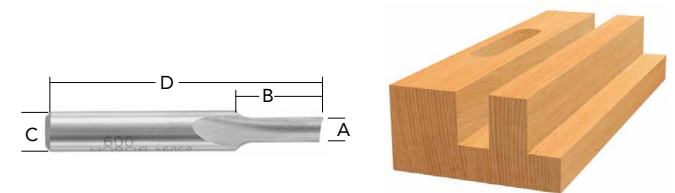

Bit No.	A Overall Dia.	B Cutting Edge Lgth.	C Shank Dia.	D Overall Length	List
85091	1/16	1/8	1/4	1-3/8	\$ 9.05
85152	1/8	5/8	1/4	1-31/32	8.25



**EDGE FORMING BITS**

**BOSCH**

**ROMAN OGEE BIT**

**Two Flutes, Carbide Tipped, Ball-bearing Pilot**  
For decorative edging and period furniture.

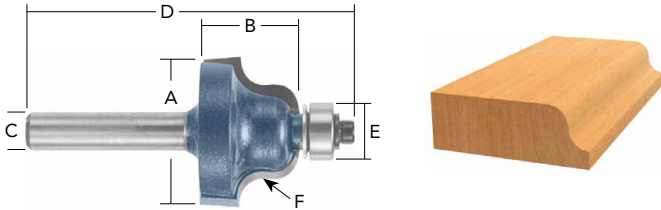

Bit. No.	A Overall Dia.	B Cutting Edge Lngth	C Shank Dia.	D Overall Length	E Brng Dia.	F Radius	List
85270M	1	5/8	1/4	2-1/8	1/2	5/32	\$ 52
85271M	1-3/8	7/8	1/4	2-1/4	1/2	1/4	55

**EDGE BEADING BIT**

**Carbide Tipped, Ball-Bearing Pilot**  
Versatile bit adds attractive edging on new pieces and matches many older molding cuts for remodeling work.

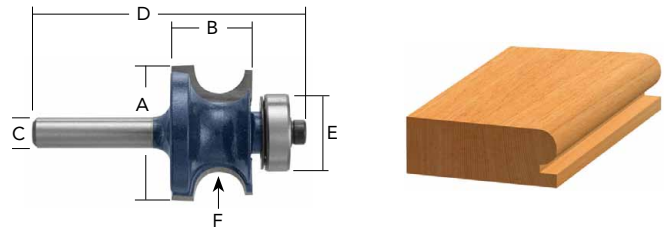

Bit. No.	A Overall Dia.	B Cutting Edge Lngth	C Shank Dia.	D Overall Length	E Brng Dia.	F Radius	List
85632M*	7/8	9/16	1/2	2-1/2	1/2	1/8	\$ 51
85666M*	1-1/8	11/16	1/4	2-1/4	1/2	3/16	49
85668M	1-1/4	3/4	1/4	2-1/4	5/8	1/4	52

**CHAMFER BITS**

**Two Flute, Carbide Tipped, Ball-Bearing Pilot**  
For beveling and decorative edging.

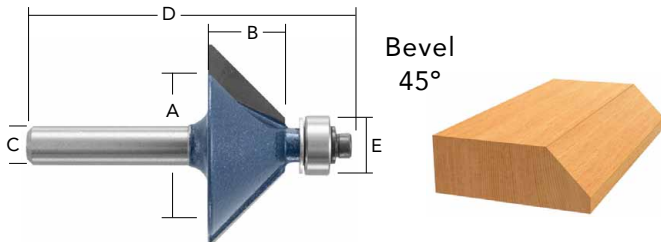

Bit No.	A Overall Dia.	B Cutting Edge Lngth	C Shank Dia.	D Overall Length	E Bearing Dia.	List
85298M	1-1/4	1/2	1/4	2	3/8	\$ 45

**BOSCH**

**EDGE FORMING BITS**

**CLASSICAL BITS**

**Carbide Tipped, Ball-Bearing Pilot**

Adds classic beauty to your product with beautiful decorative edging.

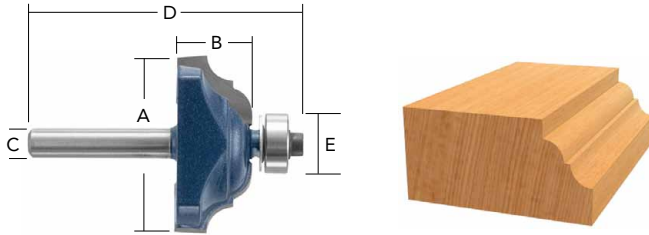

Bit No.	A Overall Dia.	B Cutting Edge Lgth.	C Shank Dia.	D Overall Length	E Bearing Dia.	List
85579M	1-1/4	1/2	1/4	2	1/2	\$ 63
85580M	1-1/4	1/2	1/2	2-3/8	1/2	68
85582M	1-1/2	5/8	1/2	2-1/2	1/2	79

**ROUNDING OVER BITS**

**Two Flutes, Carbide Tipped, Ball-Bearing Pilot**

For smooth, uniformly rounded edges. Lower depth setting produces rounded corner with decorative bead.

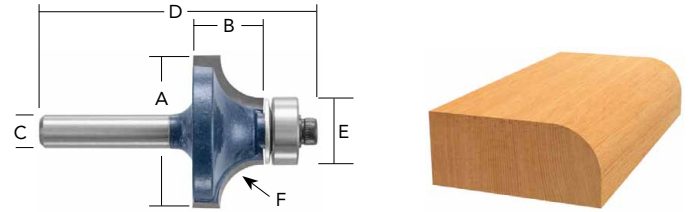

Bit No.	A Overall Dia.	B Cutting Edge Lgth.	C Shank Dia.	D Overall Length	E Brng Dia.	F Radius	List
85289M	5/8	5/16	1/4	1-3/4	1/2	1/16	\$ 44
85290M	3/4	3/8	1/4	2	1/2	1/8	45
85588M	3/4	3/8	1/2	2-5/16	1/2	1/8	51
85294M	1	1/2	1/4	2	1/2	1/4	49
85295M	1-1/8	1/2	1/4	2-1/16	1/2	5/16	48
85296M	1-1/4	5/8	1/4	2-3/16	1/2	3/8	54
85297M	1-1/2	3/4	1/4	2-1/4	1/2	1/2	50
85434M	2	1	1/2	2-7/8	1/2	3/4	87

**BEADING BITS**

**Two Flute, Carbide Tipped, Ball-Bearing Pilot**

Use wherever attractive, decorative edging is needed.

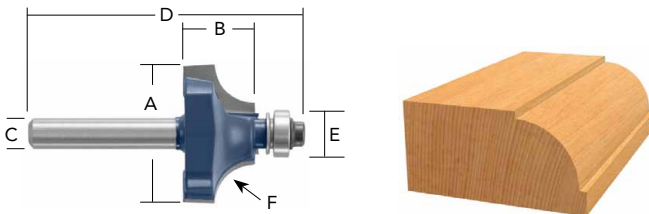

Bit No.	A Overall Dia.	B Cutting Edge Lgth.	C Shank Dia.	D Overall Length	E Brng Dia.	F Radius	List
85493M	7/8	1/2	1/4	2	3/8	3/16	\$ 43
85494M	1	1/2	1/4	2	3/8	1/4	43
85496M	1-1/4	5/8	1/4	2-3/16	3/8	3/8	47



LAMINATE TRIM BITS

BOSCH

LAMINATE TRIM BITS & CUTTERS

FLUSH TRIMMER BIT--Solid Carbide

Makes flush trim edge cut. Self-pilot.

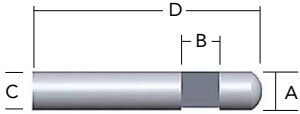

Bit No.	A Overall Dia.	B Cutting Edge Lgth	C Shank Dia.	D Overall Length	List
85285	1/4	1/4	1/4	1-1/2	\$ 15

BEVEL TRIMMER--Solid carbide

Provides 7-1/2° bevel on trim edge of plastic laminate surfaces. Self-pilot eliminates guide assembly.

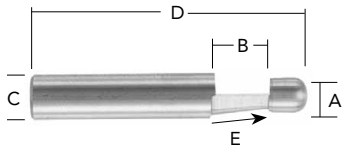

Bit No.	A Overall Dia.	B Cutting Edge Lgth.	C Shank Dia.	D Overall Lgth.	E Angle	List
85286	1/4	1/4	1/4	1-1/2	1/2	\$ 14

COMBINATION FLUSH AND BEVEL TRIMMER BIT  
Solid Carbide Tip

Can be used for 10° bevel or flush trim edge cuts. Used with router guide assembly.

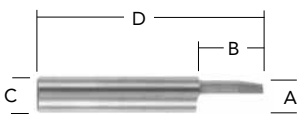

Bit No.	A Overall Dia.	B Cutting Edge Lgth	C Shank Dia.	D Overall Length	Type of Cut	List
85288	1/4	3/8	1/4	1-1/2	Flush or 10° Bevel	\$ 19

2057

LAMINATE TRIM BITS & CUTTERS

2 FLUTE LAMINATE FLUSH TRIMMING BITS

Carbide Tipped Ball-Bearing Pilot

For fast, smooth accurate trim cuts. Shielded compact ball-bearing pilot.

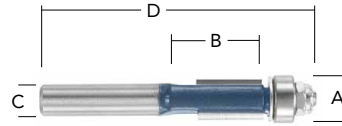

Bit No.	A Overall Dia.	B Cutting Edge Lgth	C Shank Dia.	D Overall Length	List
85269M	3/8	1/2	1/4	2-1/8	\$ 23
85266M	1/2	1	1/4	2-5/8	25
85441M	1/2	1	1/2	3-1/4	31

3 FLUTE TRIMMING BIT

Carbide Tipped, Ball-Bearing Pilot

Extra smooth cuts; for laminate trimming and trim cuts on heavier work when cutting to a templet. Can be used with two ball-bearings to widen bearing surface and reduce templet wear.

Extra Ball Bearing #2 610 906 500

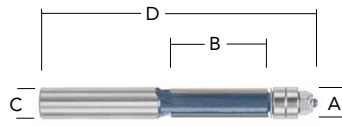

Bit No.	A Overall Dia.	B Cutting Edge Lgth	C Shank Dia.	D Overall Length	List
85602M	1/2	1-1/2	1/2	4-1/2	\$ 47

**BOSCH**

**LAMINATE TRIM BITS**

**LAMINATE TRIM BITS & CUTTERS**

**2 FLUTE ECONOMY LAMINATE TRIMMER ASSEMBLIES**

**Carbide Tipped Ball-Bearing Pilot**

For fast, accurate trim cuts. Economy priced replaceable cutter and bearing.

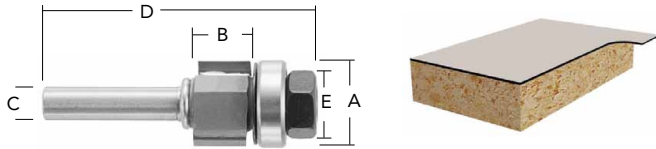

Bit No.	A Overall Dia.	B Cutting Edge Lngth	C Shank Dia.	D Overall Length	E Brng Dia.	Angle	List
85430M	5/8	3/8	1/4	1-15/16	5/8	Flush	\$ 24
85431M	5/8	3/8	1/4	1-15/16	5/8	10°	27

**4 FLUTE LAMINATE TRIMMER ASSEMBLIES**

**Carbide Tipped, Ball-Bearing Pilot**

For ultra-smooth finish trimming. Ball-bearing is equipped with glue shield. Components are individually replaceable.

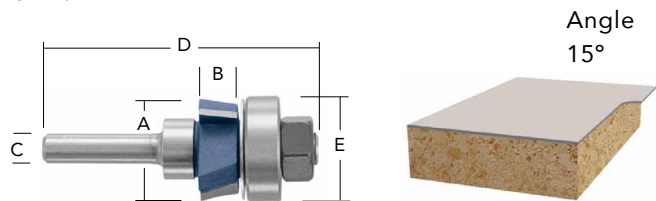

Bit No.	A Overall Dia.	B Cutting Edge Lgth.	C Shank Dia.	D Overall Lgth.	E Bearing Dia.	List
85415M	7/8	5/16	1/4	2-1/8	7/8	\$ 39

**LAMINATE TRIM BITS & CUTTERS**

**3 FLUTE LAMINATE FLUSH TRIMMING BIT**

**Carbide Tipped, Ball-Bearing Pilot**

Gives chatter free production trimming with extra smooth trim cut. Compact ball bearing assembly is equipped with glue shield.

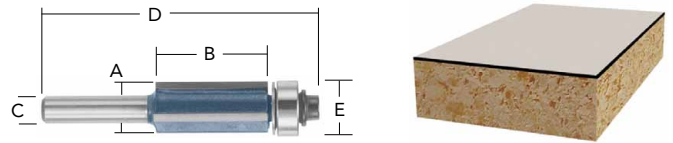

Bit No.	A Overall Dia.	B Cutting Edge Lgth	C Shank Dia.	D Overall Length	E Bearing Dia.	List
85216M	1/2	1	1/4	2-5/8	1/2	\$ 40

**SLOTING CUTTERS - 2 Wing, Carbide Tipped**

Used to make slots for "T" molding and weather stripping.



Cutter No.	A Overall Dia.	B Cutting Edge Lgth	C Shank Dia.	Depth of Cut	List
85505M	1-3/16	1/4	1/4	9/32	\$ 29

**THREE WING SLOTING CUTTERS - Carbide Tipped**

Used to make slots for "T" molding and weather stripping. 3 wings for extra strength and long life.

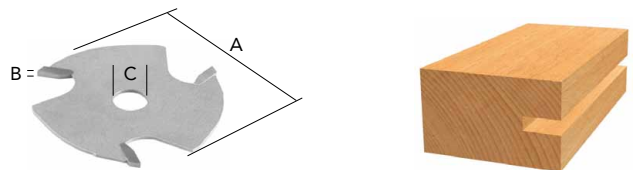

Cutter No.	A Overall Dia.	B Cutting Edge Lgth	C Shank Dia.	Depth of Cut	List
85526M	1-7/8	1/16	5/16 (bore)	1/2	\$ 24
85527M	1-7/8	5/64	5/16 (bore)	1/2	24
85529M	1-7/8	1/8	5/16 (bore)	1/2	33



## GROOVING BITS

### GROOVE FORMING BITS

#### Carbide Tipped V-groove & Scoring Bits

Excellent for door front grooving, lettering and sign work. Shear angle cutter geometry for smooth efficient cutting.

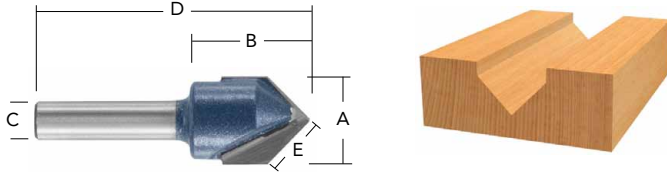

Bit No.	A Overall Dia.	B Cutting Edge Lgth	C Shank Dia.	D Overall Length	E Bevel	List
85219M	9/16	3/4	1/4	1-3/4	3/8 (45°)	\$ 27

#### Carbide Tipped Core Box Bits

Cuts rounded grooves used in a variety of applications ranging from doors to columns.

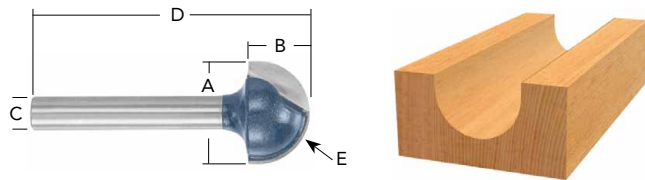

Bit No.	A Overall Dia.	B Cutting Edge Lgth	C Shank Dia.	D Overall Length	E Radius	List
85444M	1/4	1/4	1/4	1-5/8	1/8	\$ 28
85445M	3/8	1/4	1/4	1-1/2	3/16	36
85446M	1/2	3/8	1/4	1-1/2	1/4	36
85447M	5/8	7/16	1/4	1-1/64	5/16	37
85448M	3/4	7/16	1/4	2-1/32	3/8	39

### FACE FRAME/FLUSH TRIM, V-Groove Bits

Use to flush face frame to cabinet side, at the same time cut V-groove down joint of cabinet. Also as decorative profile bit, or use in finishing of laminate drawers. Carbide Tipped.

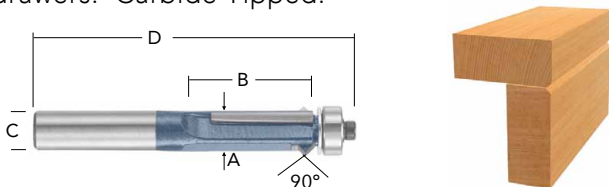

Bit No.	A Overall Dia.	B Cutting Edge Lgth	C Shank Dia.	D Overall Length	List
85646M	5/8	1	1/4	2-1/2	\$ 41
85647M	5/8	1	1/2	3	43

## MORTISE BITS & CUTTERS

### HINGE MORTISING BITS

Fast cutting bit for making mortises when work is started at the edge. Smooth finish left makes this bit ideal for surfacing operations. Also used where good chip clearance is important in application such as gummy wood.

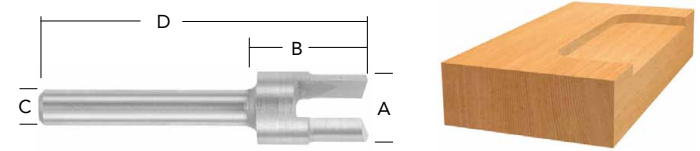

Bit No.	A Overall Dia.	B Cutting Edge Lgth	C Shank Dia.	D Overall Length	List
85159	1/2	13/32	1/4	2-1/4	\$ 17

### GROOVE FORMING BITS & CUTTERS\*

#### KEYHOLE BITS - Two Flute, Plunge and Slot Cuts

Routes mounting slots in picture frames, plaques. Solid Carbide.

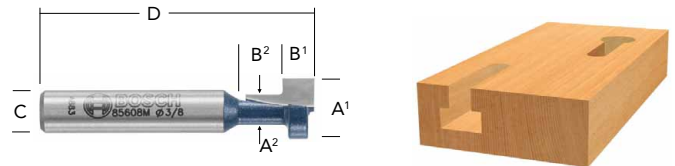

Bit No.	A1 Large Dia.	A2 Small Dia.	B Cutting Edge	C Shank Dia.	D Overall Lgth	List
85608M	3/8	3/16	3/8	1/4	1-7/8	\$ 29



**BITS & CUTTERS**

**STILE & RAIL SETS**

**CARBIDE TIPPED OGEE RAISED PANEL CUTTERS**

Produces raised panel cuts along straight and curved panel edges. Not for use in hand-held routers. Use with a router table only. Minimum recommended panel thickness is 3/4".

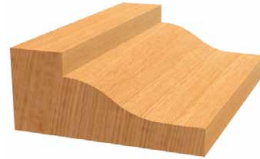
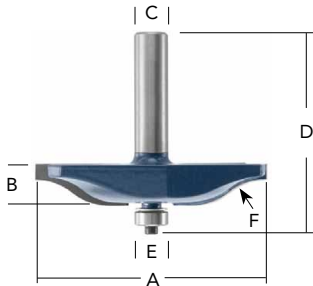

Code 85640M List \$ 170

A	B	C	D	E	F	
Overall Dia.	Cutting Edge Lngth	Shank Dia.	Overall Lngth	Brng Dia.	Radius	Cutting Width
3-3/8	9/16	1/2	2-1/2	1/2	7/8	1-7/16

**PILOT PANEL BITS WITH DRILL THROUGH POINTS**  
**Single Flute**

For windows and door cutouts in abrasive insulation materials, plywood and paneling. Drill through pilot for guiding on templet or framing after panel has been mounted. The concave grind offers a faster cut over the straight grind pilot panel bits.

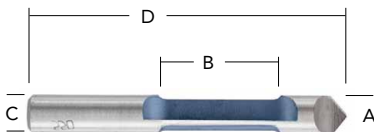

Bit No.	A Cut Dia.	B Flute Lgth.	C Shank Dia.	D Overall Lgth.	List
---------	------------	---------------	--------------	-----------------	------

**Carbide Tipped - Straight Fluted**

85244 1/4 3/4 1/4 2-9/16 \$ 19

**Carbide Tipped - Concave Fluted**

85246M 1/2 1-3/16 1/2 3-5/8 23

**STILE & RAIL SETS WITH MATCHING CUTTER ASSEMBLIES**

- Both stile & rail cuts are made with work piece face riding against the router base.
- Designed for 3/4" wood, max. wood thickness 7/8".
- Can be used in stationary or portable routers. Both Stile & Rail assemblies include ball bearing.
- Shear angle geometry, Super Sharp cutting edges, and close tolerance manufacturing combine to ensure consistently smooth, tight-fitting joints.

Note: Both 85626M & 85627M assemblies are reversible. Either can be used to make both stile & rail cuts by reassembling the cutters in a different order on the arbor. This requires one work piece to be cut "Face Up" and the other work piece "Face Down".

**Ogee Stile & Rail Set** No. 85625M List \$ 221.24  
Consists of: 85626M Ogee Stile Assembly, 85627M Ogee Rails Assembly

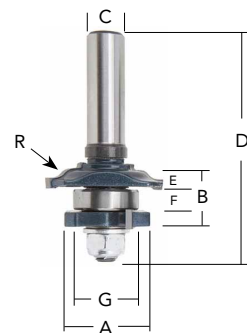
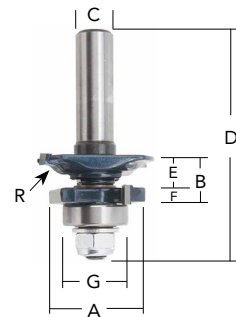

Bit No.	A Ovall Dia.	B Cutting Edge Lngth	C Shank Dia.	D Overall Lngth	E Decorative Cut Dpth.	F Kerf	G Bearing Dia.	R Radius
85626M	1-5/8	43/64	1/2	3	13/32	3	7/8	1/2
85627M	1-5/8	51/64	1/2	3	17/64	3	7/8	1/2

Order: **85625M** - Includes 85626M and 85627M











ROUTER BIT ACCESSORIES



CUTTERS & ARBORS











1/4" Shank

1/2" Shank

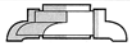
										
<b>Arbor</b>	<b>92812</b>	<b>82805</b>	<b>92813</b>	<b>82808 Ball Bearing Arbor</b>	<b>82810 Ball Bearing Arbor</b>	<b>82812 Ball Bearing Arbor</b>	<b>84628 Ball Bearing Arbor</b>	<b>82811 Ball Bearing Arbor</b>	<b>82813 Ball Bearing Arbor</b>	<b>82815 Ball Bearing Arbor</b>
<b>Shank Diameter</b>	1/4"	1/4"	1/4"	1/4"	1/4"	1/4"	1/4"	1/2"	1/2"	1/2"
<b>Arbor Diameter</b>	1/4"	1/4"	5/16"	1/4"	5/16"	5/16"	5/16"	5/16"	5/16"	8 mm
<b>Length</b>	1-3/4"	2"	1-23/32"	1-29/32"	2-5/8"	2-1/8"	3"	3"	3-9/32"	3"
<b>Ball Bearing Diameter</b>	NA	NA	NA	5/8"	7/8"	7/8"	7/8"	7/8"	7/8"	22 mm (7/8")

Item

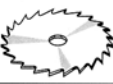
Use Correct Part Number\*

<b>Flush Trim Laminate Cutters</b> 	NA	NA	NA	<b>2-Flute</b> 85435M <b>3-Flute</b> 85509M	NA	<b>4-Flute</b> 85417M 2 required	NA	NA	NA	NA
<b>Bevel Trim Laminate Cutters</b> 	NA	NA	NA	<b>2-Flute</b> 85436M <b>3-Flute</b> 85516M 85511M 85512M	NA	NA	NA	NA	NA	NA
<b>Slotting Cutters</b> 	85506M 85507M 85508M	85505M 85506M 85507M 85508M	NA	85505M	85517M 85506M 85507M 85508M	NA 85520M	NA	85520M	NA	85630M
	NA	NA	NA	NA	NA	NA	NA	NA	NA	85623M
	NA	NA	NA	NA	NA	NA	NA	NA	NA	85624M
	NA	NA	NA	NA	NA	NA	NA	NA	NA	85628M
	NA	NA	NA	NA	NA	NA	NA	NA	NA	NA
<b>3-Wing Cutters</b> 	NA	NA	85526M 85527M 85528M 85529M	NA	NA	NA	85610	85609M 85610M 85526M 85527M 85528M 85529M	NA	85610
<b>Trim Saws</b> 	NA	NA	92837	NA	92837	NA	NA	NA	NA	NA
<b>Ball Bearing Assemblies</b> 	NA	NA	NA	Regular 5/8 OD 3600900506  Oversized 1-3/16 OD 82921	Regular 7/8 OD 3600900514  Oversized 1-1/16 OD 3600900525	Regular 7/8 OD 3600900514	Regular 7/8 OD 3600900514	Regular 7/8 OD 3600900514  Oversized 1-1/16 OD 3600900525	Regular 7/8 OD 3600900514	Regular 22 mm (7/8) 3600900514

Note: Bits must be inserted full length of collet.

M indicates micrograin bit.

Use only router bits and router accessories specifically designed for your router.

All specifications are in inches unless noted otherwise.

\* Cutters are designed to fit specific arbor(s). Match cutter number to arbor number using the vertical column.



**ROUTER BIT COMPONENT PARTS**

Bit Number	Bearing	Dust Shield	Lock Screw	Lock Washer	Washer	Nut
84442M 85579M 85604M 85205M 85580M 85605M 85206M 85581M 85606M 85207M 85582M 85607M 85218M 85583M 85614M 85270M 85584M 85615M 85271M 85585M 85616M 85289M 85586M 85631M 85290M 85587M 85632M 85293M 85588M 85637M 85294M 85590M 85638M 85295M 85591M 85639M 85296M 85592M 85640M 85297M 85594M 85647M 85298M 85595M 85649M 85434M 85596M 85666M 85441M 85597M 85667M	2 610 906 500 (3/16 ID, 1/2 OD)  Oversize Bearing 3 600 905 503 (3/16 ID, 5/8 OD)	3 600 120 500	3 603 433 507	NA	NA	NA
85217M	3 600 900 523 (6mm ID, 19mm OD)	3 600 120 506	3 603 415 551	3 600 151 502	3 600 100 517	NA
85210M 85668M 85211M 85669M 85212M	Oversize Bearing 3 600 905 503 (3/16 ID, 5/8 OD)	3 600 120 500	3 603 433 507	NA	NA	NA
85601M 85602M	2 610 906 500 (3/16 ID, 1/2 OD) Non-marring Bearing NMB004, 3/16 ID, 1/2 OD	3 600 120 500	NA	NA	Spacer 3 600 400 504	3 603 301 518
85621M 85626M 85622M 85627M	3 600 900 514 (8mm ID, 22mm OD)	NA	NA	Shims (5/pkg) 3 607 000 533	2 916 011 016	2 915 061 005
85216M 85267M 85269M 85266M 85268M	2 610 906 500 Replacement Bearing 3 600 900 507 (1/8 ID, 3/8 OD)	3 600 120 509	NA	NA	NA	3 603 301 503
85414M 85415M 85416M	3 600 900 514 (8mm ID, 22mm OD)	3 600 120 504	NA	NA	Spacer (85416M) 3 600 200 502	3 603 301 509
85420M 85422M 85421M 85423M	3 600 900 506 (1/4 ID, 5/8 OD) Non-marring Bearing NMB005, 1/4 ID, 5/8 OD	NA	NA	Spacer 3 600 222 500	Spacer 3 600 200 502	3 603 301 502
85430M 85431M	3 600 900 506 (1/4 ID, 5/8 OD) Non-marring Bearing NMB005, 1/4 ID, 5/8 OD	3 600 120 502	NA	NA	NA	3 603 301 502
85493M 85496M 85600M 85494M 85497M 85495M 85599M	3 600 900 501 (3/16 ID, 3/8 OD)	3 600 120 507	3 603 433 507	NA	NA	NA
85612M	3 600 905 502 (5mm ID, 19mm OD)	3 600 120 506	3 603 433 507	NA	NA	NA
85452M 85656M 85685M 85453M 85664M 85687M 85650M 85665M 85689M 85653M 85682M 85691M	3 600 905 504 (1/4 ID, 3/4 OD) Non-marring Bearing NMB006, 1/4 ID, 3/4 OD	3 600 120 507	3 603 415 55	3 600 100 517	NA	NA
85651M 85657M 85684M 85654M 85681M	3 600 900 506 (1/4 ID, 5/8 OD) Non-marring Bearing NMB005, 1/4 ID, 5/8 OD	3 600 120 507	3 603 415 551	3 600 100 517	NA	NA
85652M 85680M 85688M 85655M 85683M 85690M 85658M 85686M	3 600 905 505 (1/4 ID, 3/4 OD)	3 600 120 508	3 603 415 551	3 600 100 517	NA	NA
85659M 85661M	3 600 200 514 (1/4 ID, 3/4 OD) Non-marring Bearing NMB006, 1/4 ID, 3/4 OD	3 600 120 508	3 603 415 551	3 600 100 517	NA	NA
85267M	2 610 906 500 Bearing	NA	NA	NA	NA	NA



**PLUNGE ROUTER BITS**

**AMANA**

**STRAIGHT PLUNGE CUTTING BITS**



**1/4" Shank - Single Flute**

Tool No.	Cutting Dia.	Cutting Length	Shank Dia.	Overall Length	List
45100	1/8	7/16	1/4	2	\$ 17.39
45102	3/16	7/16	1/4	2	17.49
45108	1/4	1	1/4	2-1/4	19.11



**1/2" Shank - Single Flute**

Tool No.	Cutting Dia.	Cutting Length	Shank Dia.	Overall Length	List
45302	3/8	1	1/2	2-3/4	\$ 21.64



**1/4" Shank - 2 Flute**

Tool No.	Cutting Dia.	Cutting Length	Shank Dia.	Overall Length	List
45200*∞	1/8	7/16	1/4	2	\$ 18.55
45202*	3/16	7/16	1/4	2	19.92
45204-	1/4	1/2	1/4	2	18.30
45208	1/4	3/4	1/4	2	18.75
45210	1/4	1	1/4	2-1/4	19.36
45211§	1/4	1	1/4	2-7/8	22.65
45218	3/8	1	1/4	2-1/4	21.38
45226	1/2	1	1/4	2-1/8	22.85
45228	5/8	3/4	1/4	2	23.96
45230	3/4	3/4	1/4	2	26.44

**STRAIGHT PLUNGE CUTTING BITS**

**1/2" Shank - 2 Flute**



Tool No.	Cutting Dia.	Cutting Length	Shank Dia.	Overall Length	List
45408*	1/4	3/4	1/2	2-1/2	\$ 24.26
45412	5/16	1	1/2	2-3/4	22.85
45413	3/8	3/4	1/2	2-1/2	22.55
45414	3/8	1	1/2	2-3/4	22.55
45418	1/2	1	1/2	2-5/8	22.55
45420	1/2	1-1/4	1/2	2-7/8	22.70
45422	1/2	1-1/2	1/2	3-1/8	23.96
45426	1/2	2	1/2	4-1/4	31.04
45427§	1/2	2-1/2	1/2	4-1/2	42.66
45432	5/8	1-1/4	1/2	2-7/8	28.26
45440	3/4	1-1/4	1/2	2-7/8	29.93
45442	3/4	1-1/2	1/2	3-1/8	33.41
45448	1	1-1/4	1/2	2-7/8	36.04

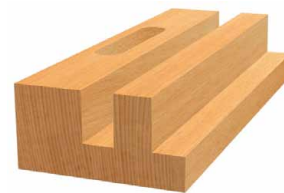

\* With solid carbide cutting edge  
 § Not guaranteed due to extreme length  
 ∞ Not guaranteed due to extreme diameter

**AMANA**

**PLUNGE ROUTER BITS**

**STAGGER TOOTH PLUNGE CUTTING BITS**

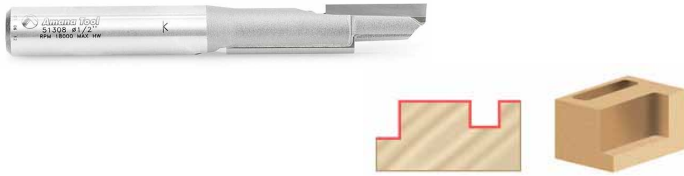

Tool No.	Cutting Dia.	Shank Dia.	Cutting Length	Overall Length	List
51308	1/2	1/2	2	4-1/4	\$ 32.76

**MORTISING BIT - 2 Flute**

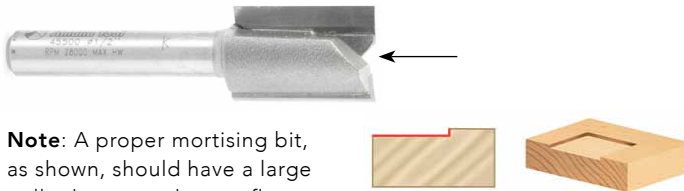

**Note:** A proper mortising bit, as shown, should have a large gullet between the two flutes, indicated with the arrow.

Tool No.	Cutting Dia.	Cutting Length	Shank Dia.	Overall Length	List
45500	1/2	3/4	1/4	2	\$ 20.67

**CLASSICAL BITS**

With Ball-Bearing Guide - 2 Flute

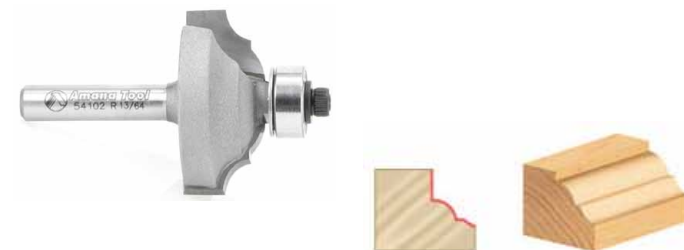

Code	Large Dia.	Rad 1	Rad 2	Carbide Height	OA Length	Shank Dia.	List
54102	1-1/4	5/16	13/64	1/2	2-1/16	1/4	\$ 63.32

Replacement Bearing No. 47706

**NO-FILE FLUSH TRIM BIT**

with Ball-Bearing Guide

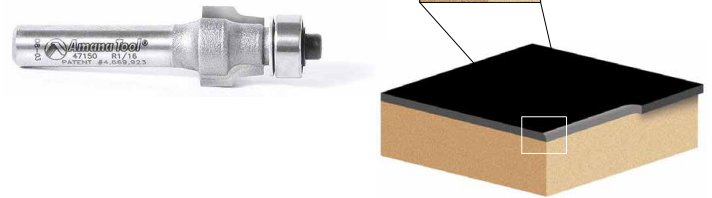

New "No-File™" Bit eliminates hand filing of laminates that normally follows trimming. They will flush trim the laminate and "break" the sharp edges all in one pass. Carbide tip.

Code	Dia.	Cut Length	Shank Dia.	List/ea
47150	1/2"	3/8"	1/4"	\$ 36.60
47152	1/2"	3/8"	1/2"	37.46

**HELIX LAMINATE TRIMMER - 2 Flute**

With Ball-Bearing Guide



Tool No.	Type of Cut	Flutes	Cutting Dia.	Cutting Length	Shank Dia.	Overall Length	List
47180	Flush	2	5/8	5/8	1/4	2	\$ 31.39
47184	15° Bvl	2	3/4	3/8	1/4	2	34.37

Replacement Bearing for 47180 is 47712  
Replacement Bearing for 47184 is 47714





**ROUTER BITS**

**AMANA**

**FLUSH TRIM BITS**

With Ball-Bearing Guide



**2 Flute**

Tool No.	Flutes	Cutting Dia.	Cutting Length	Shank Dia.	Overall Length	List
47090*	2	1/4	1/2	1/4	2-1/4	\$ 32.60
47092*	2	1/4	1	1/4	2-1/2	33.92
47100	2	3/8	1	1/4	2-5/8	22.70
47102	2	3/8	1/2	1/4	2-1/8	22.29
47104	2	1/2	1	1/4	2-5/8	22.19
47106	2	1/2	1/2	1/4	2-1/4	21.74
47108	2	1/2	1	1/2	3-1/4	23.91

\* 1/4" diameter for closer inside corner cutting.

**3 Flute**

Tool No.	Flutes	Cutting Dia.	Cutting Length	Shank Dia.	Overall Length	List
47114	3	1/2	1	1/4	2-5/8	\$ 30.08

Replacement Bearings:

- 1/4" dia. = 47723
- 3/8" dia. = 47702
- 1/2" dia. = 47706

**EXTRA LONG FLUSH TRIM BIT**



Tool No.	Flutes	Cutting Dia.	Cutting Length	Shank Dia.	Overall Length	List
47124	2	1/2	1-1/2	1/2	3-7/8	\$ 36.50

Replacement bearing(s) 47706

**FLUSH TRIM "V" GROOVE BITS - 2 Flute**

With Ball-Bearing Guide



Tool No.	Flutes	Cutting Dia.	Cutting Length	Shank Dia.	Overall Length	List
47160	2	5/8	1	1/4	2-1/2	\$ 39.73
47162	2	5/8	1	1/2	3	42.66

Replacement bearing 47706

**"V" GROOVE BIT - 2 Flute**

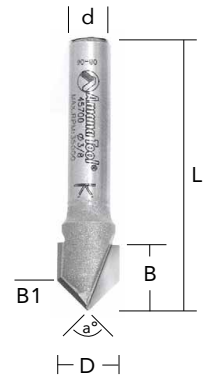
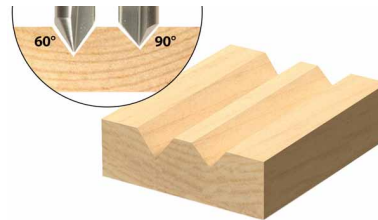

Code	a°	D	B	B1	d	L	List
45700	90°	3/8	7/16	3/16	1/4	1-5/8	\$ 31.39
45705	60°	1/2	5/8	7/16	1/4	1-3/4	39.38

**FLUSH TRIM PLUNGE BITS - 2 Flute**

With Upper Ball-Bearing

Very useful for template and pattern routing where the template is **on top** of the workpiece. Ball-bearing guide rides against the template for an exact duplication. If used on a router table, the pattern will be on the bottom, below the workpiece.



Tool No.	Cutting Dia.	Cutting Length	Shank Dia.	Overall Length	List
45460	1/2	1	1/4	2-1/2	\$ 35.13
45464	3/4	1	1/4	2-1/2	38.52
45468	1-1/8	1-1/2	1/2	3-1/2	81.03

20

**AMANA**

**CHAMFER BITS - 2 Flute**  
With Ball-Bearing Guide

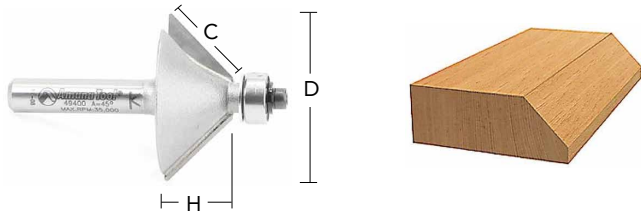

Tool No.	Degree of Angle	'D' Large Dia.	'H' Carb. Ht.	'C' Cut. Lngth	Shank Dia.	OA Length	List
49400	45°	1-1/4	1/2	5/8	1/4	2	\$ 39.38
49402	45°	1-1/4	1/2	5/8	1/2	2-3/8	40.59
49412	30°	1-3/8	3/4	7/8	1/4	2-1/4	43.07

**BEVEL TRIM BITS - 3 Flute**



Tool No.	Bevel Degree	Flutes	Carbide Height	Shank Dia.	Overall Length	List
47300	23°	3	7/16	1/4	1-7/8	\$ 34.68
47302	7°	3	7/16	1/4	2	36.80

**ROUTER BITS**

**BEADING BITS - 2 Flute**  
With Ball-Bearing Guide



Tool No.	Rad.	Large Dia.	Carb. Ht.	Shank Dia.	Ov/all Length	List
49604	1/4	1	1/2	1/4	2	\$ 42.06
49612	3/8	1-1/4	5/8	1/4	2-3/16	44.03

Replacement Bearing No. 47702

**BULL NOSE RADIUS BITS - 2 Flute**

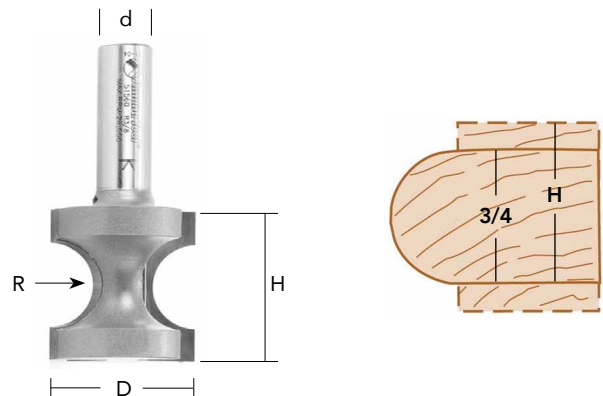

Tool No.	'R' Radius	'H' Cutting Height	'D' Dia.	OA Length	'd' Shank Dia.	List
51560	3/8	1-5/16	1-1/4	2-3/4	1/2	\$ 108.78

Material thickness: 3/4. Denotes thickness of material on which a full 180 round over can be accomplished.



**EDGE FORMING BITS**

**AMANA**

**CORNER ROUNDING BITS - 2 Flute**

With Ball-Bearing Guide

1/16" to 1-1/2" Radius

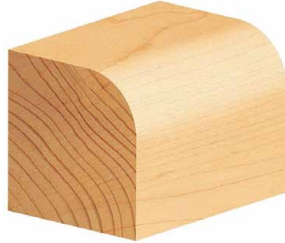

Tool No.	Radius	Large Dia.	Carbide Height	Shank Dia.	Overall Length	List
49492	1/16	5/8	5/16	1/4	1-3/4	\$ 43.17
49496	1/8	3/4	3/8	1/4	2	41.45
49499	5/32	3/4	3/8	1/4	2	45.14
49504	1/4	1	1/2	1/4	2	42.06
49506	1/4	1	1/2	1/2	2-7/16	42.66
49508	5/16	1-1/8	1/2	1/4	2-1/16	44.94
49510	5/16	1-1/8	1/2	1/2	2-7/16	46.30
49512	3/8	1-1/4	5/8	1/4	2-3/16	44.03
49514	3/8	1-1/4	5/8	1/2	2-9/16	45.50
49516	1/2	1-1/2	3/4	1/4	2-1/4	48.48
49518	1/2	1-1/2	3/4	1/2	2-5/8	49.89
49519	5/8	1-3/4	7/8	1/2	2-3/4	74.41
49520	3/4	2	1	1/2	2-7/8	79.11
49522*	1	2-1/2	1-1/4	1/2	3-3/16	153.52
49526*	1-1/2	3-1/2	1-3/4	1/2	3-5/8	238.80

Replacement Bearing 47706

\* Not guaranteed due to extreme diameter and radius. For best results it is recommended to use a smaller radius bit or chamfer the material prior to using these large radius tools. Tool life will be prolonged and a smoother finish will result.

**COVE BITS - 2 Flute**

With Ball-Bearing Guide

3/16" to 1/2" Radius



Tool No.	Rad.	Large Dia.	Carbide Height	Shank Dia.	OA Length	List
49100	3/16	3/4	9/16	1/4	2	\$ 48.58
49104	1/4	7/8	9/16	1/4	2	46.46
49112	3/8	1-1/8	9/16	1/4	2	46.81
49116	1/2	1-3/8	3/4	1/4	2-1/4	52.42
49118	1/2	1-3/8	3/4	1/2	2-1/2	53.43

Replacement Bearings:

Tool No. 49122 use 47706.

**CLASSICAL COVE BITS - 2 Flute**

With Ball-Bearing Guide



Tool No.	Large Dia.	Rad.	Carbide Height	OA Lngth	Shank Dia.	List
54150	1-3/8	5/16	5/8	2-1/2	1/2	\$ 74.31

Replacement Bearing 47706

**AMANA**

**DOUBLE ROMAN OGEE BITS - 2 Flute**

With Ball-Bearing Guide

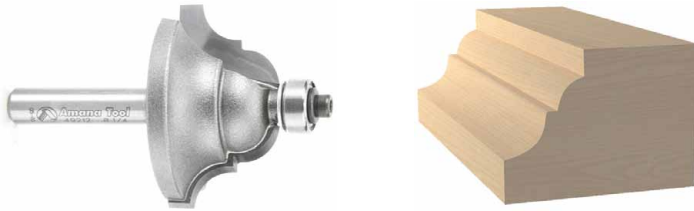

Tool No.	Large Dia.	Each Radius	Carbide Height	OA Length	Shank Dia.	List
49212	1-3/8	1/4	7/8	2-1/4	1/4	\$ 68.93
49214	1-3/8	1/4	7/8	2-5/8	1/2	69.91

**BEVEL TRIM - 2 Flute**

With Ball-Bearing Guide



Tool No.	Angle Deg.	Di.	Cutting Height	OA Length	Shank Dia.	List
47200	15°	5/8	9/32	1-7/8	1/4	\$ 26.84

**ROUTER ARBORS WITH HEX NUT AND WASHERS**



Application: 2 and 3-wing slotting assemblies and single 4-wing trim cutter assemblies.

Code	D	B	C	d	A	List
47600	5/16-24 NF	7/8	2-3/8	1/4	1-1/4	\$ 5.56
47604	5/16-24 NF	7/8	2-3/8	1/2	1-1/2	5.56

**ROUTER BITS**

**ROMAN OGEE BITS - 2 Flute**

With Ball-Bearing Guide



Tool No.	Large Dia.	Each Radius	Carbide Height	OA Length	Shank Dia.	List
49200	1	5/32	5/8	2-1/8	1/4	\$ 50.30
49204	1-3/8	1/4	7/8	2-1/4	1/2	54.04
49206	1-3/8	1/4	7/8	2-5/8	1/2	56.77

**PANEL PILOT BITS - 1 Flute**

Solid Carbide



51200



51202

Tool No.	Type of Cut	Cut. Dia.	Shank Dia.	Cut. Length	Overall Length	List
51200	Flush	1/4	1/4	1/4	1-1/2	\$ 15.17
51202	7°	1/4	1/4	1/4	1-1/2	15.17

**ROUTER BITS**

**AMANA**

**RABBETING BITS - 2 Flute - Depth of Rabbet 3/8"**  
With Ball-Bearing Guide

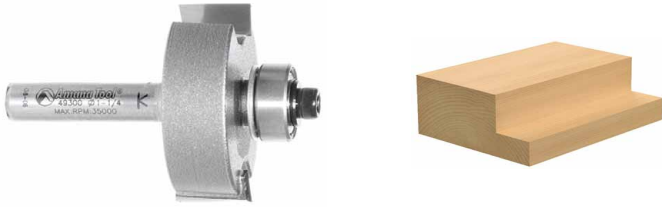

Tool No.	Cutting Dia.	Cutting Length	Shank Dia.	Overall Length	List
49300	1-1/4	1/2	1/4	2	\$ 40.09
49302	1-1/4	1/2	1/2	2-3/8	42.31

Replacement Bearings:

3/8 Rabbet	47706	7/16 Rabbet	47702
------------	-------	-------------	-------

**RABBETING BITS - 2 Flute**

With 4 Ball-Bearings  
Four Different Depth of Racht



Tool No.	Cutting Dia.	Cutting Length	Shank Dia.	Overall Length	List
49340	1-3/8	1/2	1/4	2	\$ 54.44
49350	1-3/8	1/2	1/2	2-3/8	54.44

Replacement Bearings:

1/2 Rabbet	47702
7/16 Rabbet	47706

**CORNER BEADING BITS - 2 Flute**  
With Ball-Bearing Guide

Particularly suitable for antique reproductions and restoration projects.

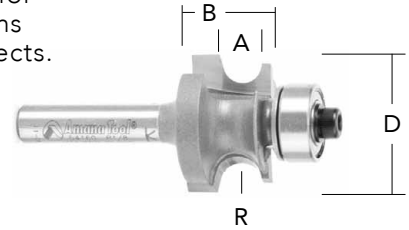

Tool No.	'R' Radius	'D' Large Dia.	'A' Opening	'B' Carbide Height	Shank Dia.	OA Length	List
54160	1/8	7/8	1/4	9/16	1/4	2-1/8	\$ 46.30
54164	3/16	1-1/8	3/8	11/16	1/4	2-1/4	52.27

Replacement bearing for 54160 use 47706.

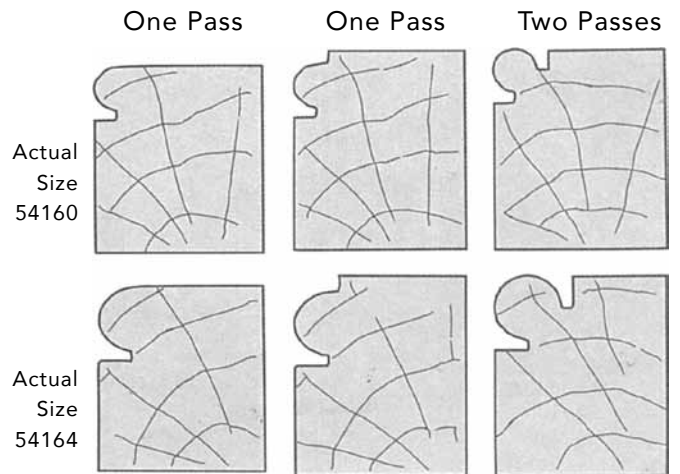

**SPECIAL AMEROCK**  
**HINGE BITS - 2 Flute**

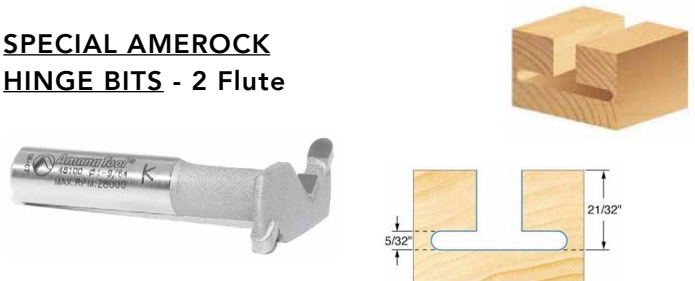

Tool No.	Cutting Dia.	Cutting Length	Shank Dia.	Overall Length	List
48100	1-1/8	21/32	3/8	2	\$ 39.73
48102	1-19/32	21/32	3/8	2	43.02

\* NOTE: These bits are not guaranteed due to extreme length.



**AMANA**

**ROUTER BITS**

**3 WING SLOTING CUTTERS**

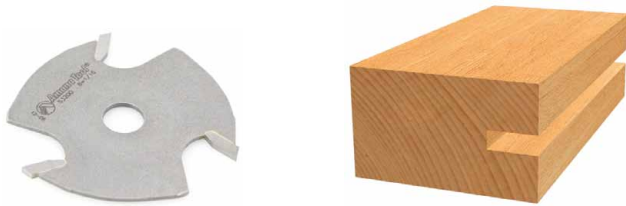

Tool No.	Kerf	Dia.	Bore	List
53200	1/16	1-7/8	5/16	\$ 22.24
53202	5/64	1-7/8	5/16	22.24
53204	3/32	1-7/8	5/16	22.90
53210	1/4	1-7/8	5/16	26.29

**SLOTING CUTTER ASSEMBLIES**

3 Wing  
1/2" Depth of Cut  
1/4" Shank,  
1-7/8" Diameter  
2-1/8" Overall Length

Replacement Arbors:  
1/4" shank - 47600  
1/2" shank - 47604



Code	Kerf	List
53400	1/16"	\$ 32.60
53402	5/64"	33.01
53406	1/8"	35.39
53407*	5/32"	36.24
53408	3/16"	36.24

**Note:** All above assemblies include cutter, arbor and ball-bearing and are ready to use.  
\* 5/32 size also used for 'biscuit-joint' cutting.

**DOVETAIL BITS - 2 Flute**



Tool No.	Degree	Cutting Dia.	Carbide Height	Shank Dia.	Overall Length	List
45804	14°	1/2	1/2	1/4	1-3/4	\$ 24.42
45806	14°	1/2	1/2	1/2	2-3/8	27.50

**CORE BOX BITS - 2 Flute**



Tool No.	Radius	Cutting Dia.	Carbide Height	Shank Dia.	Overall Length	List
45906	3/16	3/8	1/4	1/4	1-1/2	\$ 33.26
45910	1/4	1/2	3/8	1/4	1-1/2	34.17
45918	3/8	3/4	7/16	1/4	1-3/4	36.50
45920	3/8	3/4	7/16	1/2	2	48.78
45926	1/2	1	11/16	1/2	2-1/8	71.12
45928	5/8	1-1/4	3/4	1/2	2-5/16	84.67

**OGEE FILLET - 2 Flute**

With Ball-Bearing Guide  
(Max RPM 18 = 18,000)



Tool No.	Dia.	Each Radius	Cutting Height	OA Length	Shank Dia.	List
54110	1-3/8	5/32	1/2	2-1/16	1/4	\$ 75.42



ROUTER BIT PARTS

AMANA

AMANA ROUTER BITS REPLACEMENT PARTS

STEEL BALL BEARING GUIDES

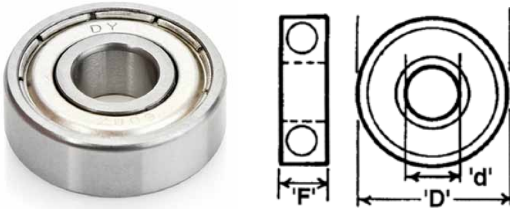

Amana uses only the finest **industrial quality precision ball-bearings** available. Bearings are double steel shielded for extra rigidity and to inhibit dust. A special high-performance, high-temperature grease is used for maximum life.

**Note:** Solvents should not be used to clean ball-bearings, as this will deteriorate the special grease. 'Frozen' bearings (ones that do not rotate freely), should be replaced immediately.

FRACTIONAL - LISTED BY SIZE



Tool No.	'd' Inside Dia.	'D' Outside Dia.	'F' Face Width	Application	List
47723	1/8	1/4	.110(7/64)	47090, 47092 1/4" diameter trim bits	\$ 9.60
47702	3/16	3/8	.124(1/8)	3/8" diameter flush trim, all beading bits (49300/49302), 49340, 49350, 49540, 49542, 49550, many types of form bits	6.12
47706	3/16	1/2	.195(3/16)	Our most popular bearing. Fits 1/2" diameter flush trim, some bevel trim, all corner rounds, raised panel, rabbit, ovolo, many types of form bits, and 51570, 54160, 54162, 54198, 54370, 54200, 54220	5.06
47712	1/4	5/8	.195(3/16)	45462, 45476, 45478, 45479, 45809, 45811, 47180, 51530, 51532, 51534, 54188, 54190, 54192, 54194, 54296, 54324, 54350, 54352, 54354, 54356, 57100, 57106, 57112, "RC" series bevel trim bits	5.96