

JORGENSEN CLAMPS

MINI STEEL BAR CLAMP

3700-LD Series, Light Duty

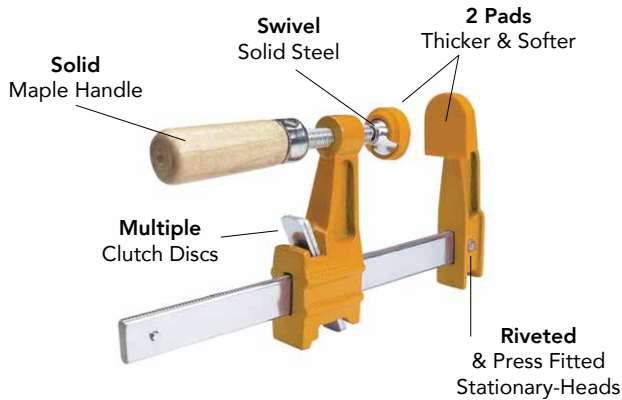

- Reach: 2", Bar: 5/8" x 3/16"
- Castings: malleable iron, orange baked enamel finish
- Screw: 5/16" diameter, cold-drawn steel
- Multiple-clutch-discs: hardened, plated, rounded edge, high-carbon steel
- Handle: Solid Maple, Pads: Thick, soft durable plastic
- Swivel: 3/4" diameter, Load Limit: 300 lbs.
- Clamps rest parallel on work surface for ease of work placement and adjustment

Code	Opening Cap	Ctn	List/ea
3704LD	4"	4 ea.	\$ 8.85
3708LD	8"	4	9.40

ONE-HANDED BAR CLAMP

33000 Series



Available in 3 bar lengths: 12", 18", 24"

Fast, easy one-handed clamping. Dual Durometer Handle for comfort. Non-marring jaws. Easy release. Reverses for use as a spreader. Bar: 3/4" x 1/4".

Code	Description	Ctn	List/ea
33412	12" Bar Clamp	6 ea.	\$ 31.58
33418	18" Bar Clamp	6	40.07
33424	24" Bar Clamp	6	39.18

STEEL BAR CLAMP - Heavy Duty

3700-HD Series

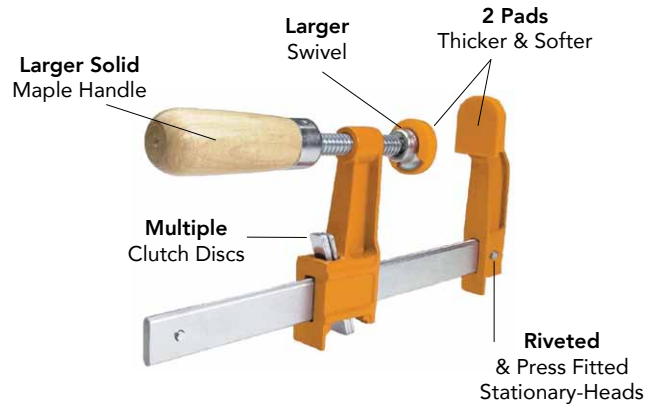

- Reach: 3", Bar: 1" x 5/16"
- Castings: malleable iron, orange baked enamel finish
- Screw: 1/2" diameter, cold-drawn steel with special, smoothly cut ACME threads
- Multiple-clutch-discs: hardened, plated, rounded edge, high-carbon steel
- Handle: Solid Maple, Pads: Thick, soft durable plastic
- Swivel: 1-3/16" diameter with steel internal-tooth washers for positive "stay-on" power
- Load Limit: 1000 lbs.

Code	Opening Cap	Ctn	List/ea
3724HD	24"	4 ea.	\$ 23.83
3736HD	36"	4	34.26

CLAMPS

STEEL BAR CLAMPS

Adjustable

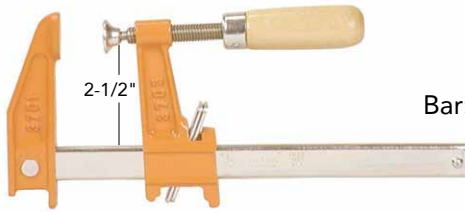

3700 Series

Bar: 1/4" x 3/4"

Load: 600 lb. clamp pressure

Strong, lightweight, with instant-acting multiple disc clutch. 2-1/2" reach. This clamp is instantly adjustable within its capacity range. Operates much faster than conventional "C" clamps; ideal for use in close quarters. Best grade malleable iron, orange colored baked enamel finish. Hardened steel clutch discs, plated and reversible.

Code	Max. Opening	List/ea
3706	6"	\$ 17.75
3712	12"	17.06
3718	18"	18.85
3724	24"	22.65
3730	30"	28.85
3736	36"	28.91

STEEL BAR CLAMPS

Adjustable

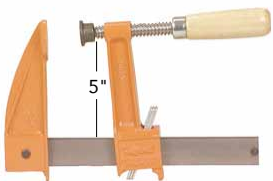

4500 Series

Bar: 1-3/8" x 5/16"

Load: 1200 lb. clamp pressure

With instant-acting Multiple-Disc Clutch. Greater reach is afforded in this design, the screw being 5" from the edge of the bar. The Multiple-Disc Clutch grips the bar automatically at any point; will not slip, easily released, permits the sliding-head to be zipped to position against the work, the screw being used only to apply or release final pressure. Best grade iron.

Code	Max. Opening	List/ea
4506	6"	\$ 50.00
4508	8"	51.07
4512	12"	49.71
4518	18"	52.95
4524	24"	71.02

1901

I-BAR CLAMPS

Adjustable



7200 Series

Powerful "High Speed" Section Bar designed for all regular service requirements. Has instant-acting Multiple-disc clutch. This style clamp is built upon the highest quality steel available. There are no notches or other deformities in the bar - the bar retains its full strength. Bar: 1-1/2" x 5/8" x 1/8". Best grade malleable Iron. Normal load limit: 6,800 lbs.

Code	Max. Opening	List/ea
7224	2 ft.	\$ 66.01
7236	3	61.45
7248	4	79.75
7272	6	89.40
7296	8	96.71

BAR CLAMP PADS

Adjustable



Pads slip onto clamp faces of clamp fixtures and steel bar clamps to provide a protective cushion between finished wood, metal, or plastic surfaces and the pressure of metal clamp jaws. Easy to stick on and slip off, the pads protect without marring, straining, sticking, or slipping.

Code	Description	List/set
7456	Clamp Pads / 4 pads/set, 24 sets/bx	\$ 7.70

BAR CLAMP PADS

Adjustable

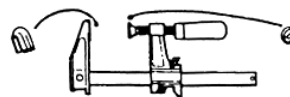

For 3700 Series bar clamps. Help protect finished wood-work and eliminate "blocks". Prevents bar clamps from slipping or marring surfaces. 8 pads per bag (4 sets).

Code	Description	List/set
7437	Clamp Pads / 4 pads/set, 24 sets/bx	\$ 6.69

PONY

CLAMPS

PONY CLAMP FIXTURES

Adjustable / Style 50



Uses 3/4" black pipe, exclusive "extended" clutch disc design. The handiest tool in any shop. For use on ordinary black pipe. Secure hold, easy release. Jaw Release: clamping faces 1-3/4" square. Normal load limit: 2,800 lbs on standard pipe, 3,800 lbs on extra heavy pipe. One set of fixtures may be used to make any number of different length bar clamps simply by mounting on different lengths of 3/4" black pipe.

Code: 50 List \$ 25.54 ea.

PONY CLAMP FIXTURES

Adjustable / Style 52



Uses 1/2" black pipe with exclusive "extended" clutch disc design. Light weight, very low cost. Vise-type sliding handle to permit working in close quarters.

Code: 52 List \$ 17.54 ea.

PONY CLAMP FIXTURES

Adjustable / Style 56



Uses 3/4" black pipe with exclusive "extended" clutch disc design. All adjustment is made from the sliding head for use in close quarters.

Code: 56 List \$ 31.19 ea.

UNIVERSAL CLAMP For Face Frames

UC76

Tap jaw to release clamp from work.



With Scuff Pads.

A new concept in clamps. Clamps each joint separately, making it possible for all clamps to be the same size. You add a clamp as the work takes shape. Eliminates the need for finding clamps of the proper length. Also eliminates the possibility of bending and bowing long rails that occur when conventional bar or pipe clamps are used.

Code	Description	List/ea
UC76	7/8" w/ Scuff Pads	\$ 31.72

"C" CLAMPS
Adjustable



For the clamp user who seeks a combination of most serviceable quality and extremely low price. Frames are liberally proportioned malleable iron for greatest strength, heat-treated for extra stiffness. Smooth, clean finish. Steel screws of adequate dia. carefully fitted. Vise-type handles. Swivels are revolving, oscillating, put on to stay. C preceding code no. means carded.

Code	Max Opening	Throat Depth	List/ea
C1430	3"	2"	\$ 7.95
1450	5"	3-1/4"	13.15
1460	6"	3-1/2"	17.23



CLAMPS

**3-WAY
EDGING CLAMP**
Adjustable



Provides a convenient practical method for applying right angle pressure to the edge or side of work. The unique three-screw design permits the right angle screw to be centered or positioned above or below the center on varying thicknesses of work. For installing or repairing molding, trim, and decorative attachments to countertops, furniture, veneers, etc. 1-1/2" opening, 2-1/2" throat.

Code: 3325 List \$ 17.50 ea.

PECK CLAMP DOG

For frame and jig assemblies. Also where temporary clamping is required.



Code	Width	Ctn	List/ea
2CD	2"	12 ea.	\$ 11.21
3CD	3"	12	12.33

PONY SPRING CLAMPS

Adjustable

When relatively light pressure is adequate, and where fast application and removal of clamps are advantageous, these spring clamps are the best answer. Jaws are heavy plated steel to prevent rust. Tips are contoured to prevent scratching or marring work surfaces and have protective covering. Handles shaped to fit the hand.



Code	Size	Ctn	List/ea
3201T	1"	12 ea.	\$ 2.55
3202T	2"	12	6.15
3203T	2-3/4"	6	14.04
3204T	4"	6	19.47

HANDSCREWS

Adjustable

Style J, Adj. Steel Spindle

The hard maple jaws will not mar and are less likely to slip than steel jaws. They have a deep throat and afford either a broad area of evenly distributed pressure or concentration at one point. Leverage of screw action gives most secure grip.



Code	Length Jaws	Opening Between Jaws	List/ea
0AD	8"	4-1/2"	\$ 29.29
1AD	10"	6"	40.92
2AD	12"	8-1/4"	46.91

CLAMPS

ADJUST-A-CLAMP from ADJUSTABLE

Pressure Adjusting Spring Clamp

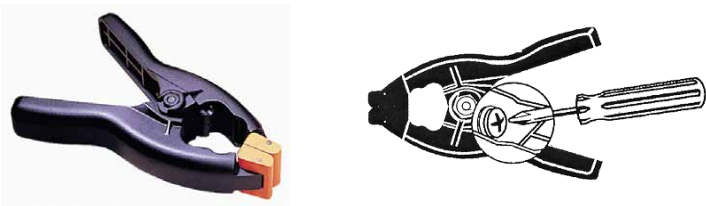

Instant opening and closing with 1 to 50 lbs. of clamping force, with the simple turn of a screw. Soft, pivoting jaw pads. Ideal for delicate gluing of models and crafts or heavy-duty work holding. Holds irregularly shaped objects and protects work pieces, without marring; in 1" and 2" openings. Jaws/Handles are strong, light-weight plastic. Spring is heavy-duty tempered steel.

Code	Opening	Jaw Length	Reach Between Jaws	Ctn	List/ea
3252	2"	6-1/2"	2-1/8"	36	\$ 7.24

PECK MITER CLAMPS

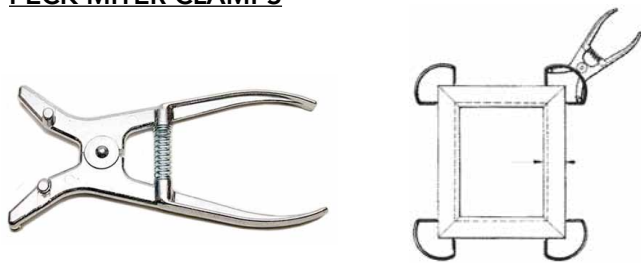

These high-quality miter clamps are made of chrome nickel steel. The points of the springs are designed for long life and to prevent excessive marks. Rings are stretched slightly with special pliers, then put into place and released. Pliers are then used with another spring on the next corner, released, and then on to the next corner.

Code	Description	List
CL-MTR-PL	Miter Clamp Pliers	\$ 117.57
R#1	Ring for 1/2" to 1-1/2" miters	8.08
R#2	Ring for 1/2" to 4" miters	8.29

CABINET CLAW from ADJUSTABLE

Install TWO stiles from 1-1/2" to 2" width and up to 1-1/2" thickness each.



Turn face frame cabinet installation into one easy process. "All-in-one" design tightens, aligns and allows pre-drilling of pilot holes and fastening.

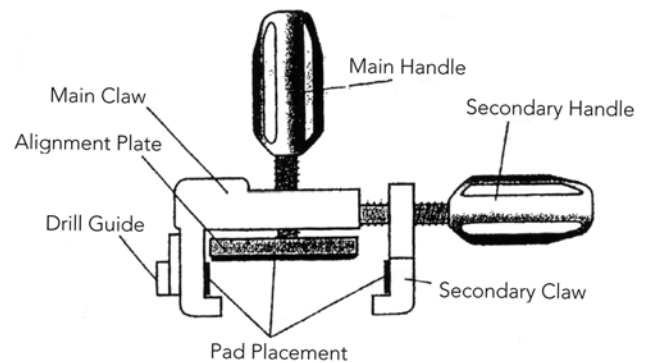

Code	Ctn	List/pr
8510-BP	1 pr.	\$ 111.40

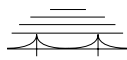

CLAMPS

BAND CLAMPS

Adjustable

Canvas band for clamping round or irregularly shaped sections like furniture frames, aircraft sections, tanks or columns.



The pre-stretched canvas band is 2" wide, easily handled, and does not kink. Cam extensions provide for easy release. Rubber pad on base protects finished surfaces and provides pressure on work immediately beneath fixture. 2,800 lb. load capacity. Malleable iron casting, baked enamel finish. Cold-drawn steel screw, 5/8" diameter. No loose parts. Lightweight.

Code	Size	Ctn	List/ea
6210	10'	6	\$ 153.13

RATCHET BAND CLAMP

Adjustable



Tie downs will clamp and hold round, square or irregular shaped objects. Can be used for furniture repair, edge-gluing, clamping picture frames, or any assembly operations. Available in both light-duty and heavy-duty styles.

Code	Load Cap	Band-Width	Length Adjusts to	Ctn	List/ea
88122	1500 lbs.	1"	15 ft.	2 ea	\$ 16.75

BAND CLAMPS

Adjustable

Nylon webbing



Lightweight, 1" wide nylon band encircles any round or irregular shape to apply pressure all around the work. For use wherever objects are to be temporarily clamped or bundled together. No knots. Place band around objects and draw snug by hand, with final pressure applied by a small wrench (included) or screwdriver. Self-locking cam affords positive hold and instant release. Nylon band is 1" wide, 15' long, and withstands loads to 1,000 lbs. Wrench and four steel corners included.

Code: 1215 15' length List \$ 24.97 ea.

3RD HAND SUPPORT SYSTEM

Fastcap

The 3rd Hand Support System and the Little Hand provide support, brace or clamp for whenever you might need an extra hand.

Uses:

- Cabinet installation
- Crown molding at angles
- Countertop backsplashes
- Installing window coverings
- Plastic Barriers
- Hanging dry wall
- Supporting ceiling paneling
- Supporting light fixtures

150 lb. Load Cap.

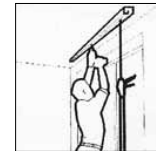

3-H-LITTLE



3-HAND-5HD

Code	Description	Range	List
3-HAND-5HD	Third Hand	5' to 12'	\$ 61.80
3-H-LITTLE	Little Hand	16.5" to 22.8"	49.54

Load Capacity: 150 lbs. (applies to each unit)

LAMINATE TOOLS

VIRUTEX EDGE TRIMMER

This tool simultaneously trims both edges of vinyl or other press-on edging. For panels 9/16" to 1-3/4" thick.



<u>Code</u>	<u>Description</u>	<u>Ctn</u>	<u>List</u>
ET93	Edge Trimmer	1 ea	\$ 42.27/ea
ET94RP	Replacement Blades (6 ea. per card)	1 set	25.16/cd

J ROLLER
Gundlach



Has strong aluminum alloy handle with lightweight comfortable grip. Rubber roller: 1-1/2" dia, 3" wide. Overall Length: 12-1/2". Pack: 1 per box.

Code: J200B List \$ 22.64 ea.

EXTENDABLE LAMINATE ROLLER
Gundlach



Features 17" to 27" extendable handle and three separate rollers with a total of 7-1/2" width. Rollers are made of long-life non-marking material. Firm grip handle. Uses: wallcoverings, plastic laminates, vinyl floorcovering.

Code: 333-AR List \$ 72.32 ea.



FILES

SAVE-EDGE FILES

Sharp, Long Lasting Files



Handy File, Dual-Cut File



Mill Coarse File

The teeth on these files have been specifically designed for use on laminate and wood materials. Specially processed in the U.S. to create a uniquely sharp and long-lasting edge.

The MILL COARSE is a single cut file (teeth cut one direction) and primarily used on laminate and wood. This file gives a smooth finish, yet removes material very well.

The HANDYFILE is a unique file with a single cut on one side and a double cut on the other side. The Handyfile handle is round. Excellent for use on all laminates and wood.

The DUAL-CUT is specifically for laminates. Mill Coarse cut on one side. Flat Coarse cut on the other side. Round handle. Flat Coarse side allows for rapid stock removal with a medium smooth finish.

Code	Description	Ctn	List/ea
7080306FC	10" Mill Coarse	12 ea.	\$ 15.70
7080308FC	12" Mill Coarse	12	20.93
7308833FC	8" Handy File	12	20.59
7308838FC	10" Handy File	12	21.57
7308840FC	8" Dual Cut	12	18.94
7308845FC	10" Dual Cut	12	22.30

SIMONDS ALL PURPOSE FILES

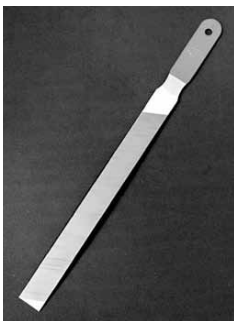

All purpose files mill smooth cut on one side, bastard fast cut on the other side. Terrific for on-the-job touch-ups or when frequent alternating between fine and coarse filing is necessary. Just flip to the other side! The spatula-shaped integral handle makes them safe and easy to use. Top quality industrial files. Made in the USA.

Code	Size	Ctn	List/ea
SM8AP	8"	1 ea.	\$ 16.82
SM10AP	10"	1	20.02

PLASTI-CUT FILES

Practical Products

Mill Cut



Fast Cut



Specially milled files for use on plastic laminate. Select the MILL cut for fast cutting and the smoothest finish. Select the FAST cut for fastest cutting and a smooth finish.

Code	Description	Ctn	List/ea
PPC8M	8" Mill	10 ea.	\$ 15.13
PPC10F	10" Fast	10	25.81
PPC10M	10" Mill	10	19.14
PPC12F	12" Fast	5	33.98
PPC12M	12" Mill	5	25.30
PPC14M	14" Mill	5	33.35

File Cross Reference Chart

Description	Save Edge	Plasti-Cut	Mercer
10" Mill Std.	6070010VA	PPC10M*	BFMB10
12" Mill Std.	6070012VA	PPC12M*	BFMB12
14" Mill Std.	6070014VA	PPC14M*	BFMB14
10" Mill Coarse	7080306FC*		
12" Mill Coarse	7080308FC*		
10" Flat Coarse	7010035FC	PPC10F*	BPLI10
12" Flat Coarse	7010038FC	PPC12F*	BPLI12
8" Dual Cut	7308840FC*		BDUA08
10" Dual Cut	7308845FC*	PC10DX	BDUA10
8" Handy File	7308833FC*		
10" Handy File	7308838FC*		

* Items we stock

KNIVES

STANLEY UTILITY KNIFE
with Retractable Blade



Front loading with 3 position retractable blade. Blade storage magazine in rear. String cutting feature in body - blade does not have to be exposed. Furnished with 3 each 11-921 heavy duty blades. Die-cast aluminum handle is durable and lightweight. 6 each per ctn.

Code	Description	List/ea
10-499	6" Length Utility Knife	\$ 11.23

STANLEY REPLACEMENT UTILITY KNIFE BLADES

Pointed, razor sharp utility knife blades. 5 per card, 10 cards per box.



Code	Size	List/cd
11-921	2-7/16" x .025"	\$ 2.47

STANLEY BLADE DISPENSER

Contains 100 utility knife blades. Wall display dispenses one at a time for safety and convenience. Holds 11-921 blades.



Code	Description	List/ea
11-921A	Blade Dispenser	\$ 30.92

STANLEY SINGLE EDGE RAZOR BLADES

Backed high carbon steel blades fit all standard razor blade tools. Carded or Bulk pack.



Code	Description	List
28-510	Carded, 10 ea/card	\$ 2.54/cd
11-515	Bulk, 100 per box	11.26/bx

PLIERS

FASTCAP END NIPPERS

Has a flush 1" wide head that can be used for cutting up to 3mm edgebanding and a variety of other applications.



- Jaws ground flush
- Very versatile
- Small and compact
- Use on soft metals and wood

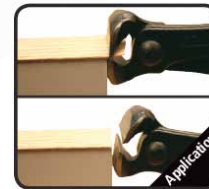

Code	Description	List/ea
PLIERS-ENDNIP	End Nippers	\$ 20.00

FASTCAP HEAVY DUTY FLUSH CUT TRIMMER

- Jaws ground flush
- Heavy Duty Cutters
- Cuts small nails and brads flush with surface
- Includes 2 PowerMags to help catch metal debris
- Not for hardened screws/fasteners



Code	Description	List/ea
PLIERS-HEAVYDUTY	Heavy Duty Flush Trimmer w/ Magnets	\$ 26.66

STANLEY PROFESSIONAL BEVELS

Hardwood handle with handy grip, brass tip, and locking device.



Blade Length: 8".
Handle Length: 5-1/2". 6 per box.

Code	Description	List/ea
46-813	Solid Hardwood T-Bevel	\$ 16.93

STANLEY DIAGONAL CUTTING PLIERS

Tempered steel, designed to provide maximum leverage and maintain sharpness. Rust resistant, foam covered handles. 6 pliers per box.



Code	Description	List/cd
84-105	6" Length Pliers	\$ 12.86



TAPE MEASURERS



POWERLOCK TAPE
With Power Return
from Stanley

POWERLOCK RULE: Mylar™ coated yellow blade. Features heavy duty Tru-Zero hook and slide lock up front for easy operation. Graduated in 16ths of an inch. Shows 32nds on first twelve inches. With belt clip.

3/4" Wide Yellow Blade

Code	Size	Ctn	List/ea
33-312	12'	6/box	\$ 25.37

Same as above but w/ Metric as well as inch.

33-158	5m / 16'	6/box	\$ 28.96
--------	----------	-------	----------

1" Wide Yellow Blade

Large and easy to read numerals and stud markings every 16 inches. Blade remains rigid up to 7'. Shown in inches.

Code	Size	Ctn	List/ea
33-425	25'	4/box	\$ 34.53

PROCARPENTER "OLD STANDBY" TAPE MEASURE

Fastcap

PS-16 (16')

PS-25 (25')



Professional tape measure with 1 inch increments.

Also features: Erasable notepad, high contrast black on white scale, heavy duty 1" blade, belt clip, pencil sharpener, dual thumb and finger locks and compact, shock-resistant rubber casing.

Code	Size	Ctn	List/ea
PS-16	16'	1	\$ 10.59
PS-25	25'	1	15.54

STANLEY TAPE MEASURER

"Contractor Grade"

This heavy duty tape measurer has a thicker, more durable Mylar™ coated blade. Yellow case has black rubber "armor."



Pack: 6

Code	Blade	List/ea
33-696*	3/4" wide x 5m, metric only	24.73

* disc when out

PMS TAPE MEASURER

Fastcap

- Erasable note pad
- Standard English rule & Metric rule
- Heavy duty rubber boot
- Common conversion charts
- Scratch resistant coating
- Easy thumb lock
- Easy read fractions to 1/16"



Code	Description	List/ea
PMS16	16'/5m Tape	\$ 10.59
PMS25	25'/8m Tape	16.32

PSSR TAPE MEASURER

Fastcap



Standard measurements that are readable when tape is extended from either right hand or left hand.

Features: Erasable notepad, pencil sharpener, Standard English rule, Easy read fractions to 1/16", Scratch resistant coating on tape, easy thumb lock, and heavy duty protective rubber boot. 12 each/ctn.

Code	Description	List/ea
PSSR-16	16' Tape	\$ 11.11

MEASURING TAPE / SCREWDRIVERS

SQUARES

STANDARD PEEL & STICK 16' TAPE

Fastcap

The Peel & Stick tape measure puts a tape rule right where you need it. The flat 16' long tape measure is printed on both sides allowing for left or right read. Simply adhere the included SpeedTape to one side of the tape and stick it on!



PS-STICK-16

Code	Ctn	List/ea
PS-STICK-16	1	\$ 18.70

POZI DRIVE SCREWDRIVERS

#2 Pozidrive for Hinges



Salice Screwdriver
D2A7XCXCP

Grass Screwdriver
98000



Screwdriver
12360

Code	Description	List/ea
D2A7XCXCP	Salice Pozidrive Screwdriver	\$ 13.65
98000	Grass Pozidrive Screwdriver	19.77
12360	Pozidrive Screwdriver	9.95

6 IN 1 SCREWDRIVER

Includes:
Phillips #1,
Phillips #2,
Slotted 4.5 and 6mm,
1/4" Hex, 5/16" Hex



12361

Code	Description	List/ea
12361	6 in 1 Screwdriver	\$ 9.95

FLAT SQUARE

Stanley

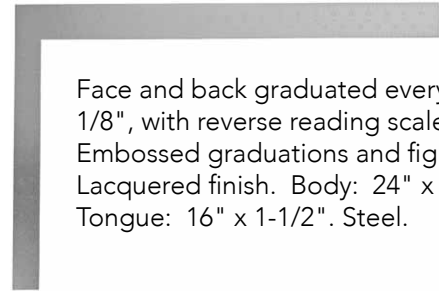

Face and back graduated every 1/8", with reverse reading scale. Embossed graduations and figures. Lacquered finish. Body: 24" x 2" Tongue: 16" x 1-1/2". Steel.

Code	Ctn	List/ea
45-500	6	\$ 9.60

COMBINATION SQUARE

Stanley



Removable grooved blade graduated 8ths, 16ths, and 32nds. Scratch awl and versatile level vial built into handle. Level vial feature offers greater visibility. O.A. Length: 12", Handle: 4-1/4".

Code	Ctn	List/ea
46-123	1	\$ 28.31

COMBINATION SQUARE/GROOVED BLADE

Stanley



Grooved blade, scratch awl and level vial included. Handle: 4-1/8", Overall Length: 12". Carded.

Code	Ctn	List/ea
46-222	6	\$ 14.09

SHARPENING STONES

TOOLS

**COMBINATION
ARKANSAS STONE**



Begin sharpening on the medium side and finish the edge on the hard, fine side. Cedar box.

<u>Code</u>	<u>Size</u>	<u>List/ea</u>
340-1500	6" x 2" x 1/2"	\$ 51.69

**ROUND EDGE
SLIP STONE**



This round edge stone is for working with curved edges and for deburring and polishing. Excellent for wood-carver's tools. Fine Arkansas.

<u>Code</u>	<u>Size</u>	<u>List/ea</u>
340-1650	4" x 2" x 1/2"	\$ 38.48

COMBINATION FILE CARD AND BRUSH



CB-88B

Heavy duty file card with wire bristles to remove stubborn metal-clogging of file teeth. For best results, pull the card across the file in the direction of the file grooves.

19 Contains a plastic bristled brush on the other side which removes most of the filings. Wire side not recommended for PLASTI-CUT files. Wooden handle. 10" in Length.

<u>Code</u>	<u>Length</u>	<u>Ctn</u>	<u>List/ea</u>
CB-88B	10"	10	\$ 19.03

**STANLEY
PRY BAR**



Forged tool steel for extra toughness, with polished and beveled cutting edges. Contoured bar - ideal for pulling nails, prying, lifting or scraping. Beveled nail slot on both ends. Blade Width: 1-3/8". O.A. Length: 12-1/2".

<u>Code</u>	<u>Ctn</u>	<u>List/ea</u>
55-515	4	\$ 14.48

STANLEY NAIL SETS



Square head, round knurled body. Alloy steel hardened and tempered. Tips are cupped and chamfered. Square head prevents rolling. Black phosphate finish. 11/32" square. Overall Length: 4". 1 per card, 6 cards/box.

<u>Code</u>	<u>Tip</u>	<u>List/cd</u>
58-111	1/32"	\$ 2.80
58-112	1/16"	2.77
58-113	3/32"	2.96

**HOLLOW SCREW
EXTRACTORS**

Turned counter-clockwise in an electric drill, this tool makes easy work of removing broken screws from wood, while leaving a clean hole that can be filled with a dowel or a plug.



Use the 1/4" model for screws up to #8 and the 3/8" model for the #10 screws and larger. Size refers to the finished hole size.

<u>Code</u>	<u>Size</u>	<u>List/ea</u>
800-3004	1/4"	\$ 23.45
800-3005	3/8"	25.25

PLANES

**STANLEY 21°
BLOCK PLANE**



The cutter rests on its seat at an angle of 21° and is fully adjustable. For thickness of shaving, rotate knurled nut. Lever adjusts evenness of shaving. Mouth is also adjustable for coarse or fine work. Overall: 6" long. Cutter width: 1-5/8".

Code	Ctn	List/ea
12-920	1	\$ 64.56

**STANLEY 12°
BLOCK PLANE**



Fully adjustable, low angle. The cutter rests at an angle of 12°. This angle makes it easy to plane across a hardwood. The mouth is adjustable for coarse or fine work. Finger grips in sides. Cutter adjusted with knurled screw. Overall: 6" long. Cutter Width: 1-3/8".

Code	Ctn	List/ea
12-960	1	\$ 65.50

**STANLEY
RABBET PLANE**



For regular and bull nose work. This plane has two seats for the cutter: one for regular work and the other for bull nose work. It is fitted with a spur, a removable depth gauge, and adjustable fence. When used in the rear seat, the cutter is adjustable. Overall: 8-1/4" long. Cutter Width: 1-1/2".

Code	Ctn	List/ea
12-978	1	\$ 93.90

**STANLEY
SMOOTHING PLANE**



These Stanley Bailey™ planes are excellent for general smoothing and fine finishing of high quality work. Cast iron bottom and sides are ground perfectly flat and true. Micro-adjustable mouth opening. Precision ground cutter.

Code	Length	Blade Width	List/ea
12-904	9-3/4"	2"	\$ 90.79

**STANLEY
SOFT FACED HAMMER**



High visibility Neon Orange

"Dead Blow"
Construction

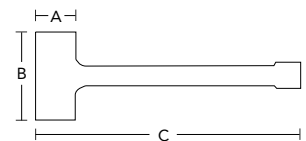

Non-sparking soft face hammers of UNICAST construction have no exposed metal. The soft face yields, will not mar surfaces or equipment & doesn't absorb liquids.

Code	A	B	C	Ctn	List/ea
57-532	2"	4-1/4"	12-3/4"	2	\$ 51.17
57-533	2-1/2"	4-3/4"	14"	4	67.64

**STANLEY
RUBBER MALLET**



Tough rubber head molded to a lacquered handle. 18 oz. Overall Length: 13-3/4". 5 per box.

Code	Ctn	List/ea
57-522	5	\$ 18.53



SCRAPERS

STANLEY PUTTY KNIFE

1-1/4" wide blade.
Nylon handle. Steel blade permanently fastened to shatter-proof handle.



Available with either stiff or flexible blades.
Carded, 5 cards/box.

<u>Code</u>	<u>Blade</u>	<u>Blade Width</u>	<u>List/ea</u>
28-140	Stiff	1-1/4"	\$ 7.68
28-240	Flexible	1-1/4"	8.53
28-242	Flexible	2"	10.26

STANLEY PAINT SCRAPER

Lightweight molded polypropylene contoured paint scrapers. Designed for long life and comfort.



<u>Code</u>	<u>Handle Size</u>	<u>Blade Type</u>	<u>Blade Width</u>	<u>Ctn</u>	<u>List/ea</u>
28-619	9"	2-edge	2-1/2"	5	\$ 8.55

STANLEY SCRAPER REPLACEMENT BLADE

This 2-edge scraper replacement blade is made of high carbon steel. Fits scraper 28-619 (Above item.)



<u>Code</u>	<u>Blade Width</u>	<u>Ctn</u>	<u>List/ea</u>
28-292	2-1/2"	5 ea.	\$ 3.54

CABINET SCRAPERS



The finest German steel. Ideal tool for refinishers. Regular rectangle, curved on opposite ends, and classic "gooseneck" shape. Use a burnisher to sharpen.

<u>Code</u>	<u>Description</u>	<u>List/ea</u>
520-5010	Rectangle, 0.8mm	\$ 8.68
520-5510	Set of 3, one of each shape	33.75

WALLET FOR CABINET SCRAPERS

This leather wallet is the best way to store your flat metal scrapers. Vinyl dividers keep the scrapers from rubbing together inside the pouch. Stores up to four scrapers. Made in France.



<u>Code</u>	<u>Description</u>	<u>List/ea</u>
845-1050	Scraper Wallet	\$ 44.53

CHISELS

STANLEY BEVEL EDGE CHISEL



Tough handle design for balance and grip. Crown shaped steel cap centers hammer blows. Blade and tang are forged from one piece of high quality cutlery grade steel. Blade 3" long. Carded, 2/box.

<u>Code</u>	<u>Width</u>	<u>OA Length</u>	<u>List/cd</u>
16-907	3/4"	9"	\$ 16.86
16-908	1"	9"	19.23

STANLEY WOOD CHISEL SETS



Set of 6 chisels. Durable storage case sits on work area for easy selection.

1 set/box.

<u>Code</u>	<u>Sizes</u>	<u>List/st</u>
16-901	1/4", 1/2", 3/4", 1" 1-1/4", 1-1/2"	\$ 101.43

APRONS

14 POCKET, DOUBLE TIER, PROFESSIONAL BIB-STYLE APRON

McGuire-Nicholas

Overall Size: 23-1/2" x 9-1/2". 100% natural cotton canvas. Five lower and 7 upper pockets, 2 bib pockets for easy pencil and pad access. Polypropylene hammer loop on right and left sides, rivet reinforced. 6 ea/box.



<u>Code</u>	<u>Description</u>	<u>List/ea</u>
C7	Bib-Apron	\$ 16.55

LONG 3 POCKET APRON

McGuire-Nicholas

Economy apron. OA length: 40". 100% blue cotton canvas. 1 large waist pocket, 2 small pencil & pad bib pockets. Extra reinforcements at stress points. Canvas loop neck and waist ties. Polybagged.



<u>Code</u>	<u>Ctn</u>	<u>List/ea</u>
30	3 ea.	\$ 13.65

12 POCKET, DOUBLE TIER, PROFESSIONAL WAIST APRON

McGuire-Nicholas



C10

Overall Size: 23" x 9-1/4". 100% natural cotton canvas. Double tier design. Polypropylene hammer loops on right and left sides. Tie straps, reinforced stitching at all stress points. Polybagged.

<u>Code</u>	<u>Ctn</u>	<u>List/ea</u>
C10	3 ea.	\$ 12.29

KNEE PADS

KNEE PADS

Alta Industries

Hook & Loop closures - infinitely adjustable for quick on/off convenience. Nylon thread is fully stitched throughout for optimum strength and durability. Uses 1-1/2" contoured foam rubber cushioning for maximum comfort and tough Cordura nylon which resists water, abrasion and deterioration.

507:

- Contoured mar-resistant capless design
- Navy Cordura® Nylon Cover
- AltaGrip™ Hook & Loop Fastening System



509AL:

- Hard White plastic cap for easy swiveling and maneuvering on work surfaces
- Navy Cordura® Nylon Cover
- AltaGrip™ Hook & Loop Fastening System



504S:

- Long, durable thick rubber Black Cap provides traction, resists skidding and protects against rocks and debris
- Black Cordura® Nylon Cover
- AltaGrip™ Hook & Loop Fastening System



<u>Code</u>	<u>Description</u>	<u>List/pr</u>
507	Strap-on Cordura Nylon Knee Pads, No Cap	\$ 25.95
509AL	Same as 507 except has polypropylene cap for greater comfort, support & protection	29.22
504S	Knee pads w/ long rubber cap	34.73

JIGS

EURO HANDLE-IT

18" Jig for Handle and Knob Drilling

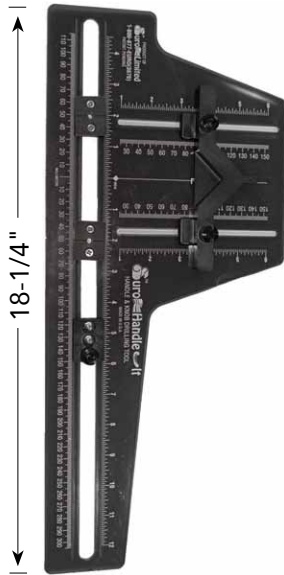

- Installs handles as large as 24" (600mm)
- Height adjustment to center of a 12" high drawer front.
- Center reference line for extra wide drawer fronts.
- Moveable positioning stops for use on drawer fronts of the same size.
- English and metric scales for use on all handles.
- V-Notch in fence for use in installing handles at a 45° angle.
- Made of Polycarbonate (jet aircraft canopy material).

EHIT
Installation
Tool



<u>Code</u>	<u>Ctn</u>	<u>List/ea</u>
EHIT	Jig for Handle and Knob Drilling	\$ 78.41
EHIT-BUSHINGS	Heat Treated Bushings Kit with screws and nuts	19.66

KREG POCKET HOLE JIG

Makes strong and fast Face Frame joints with only a hand drill!

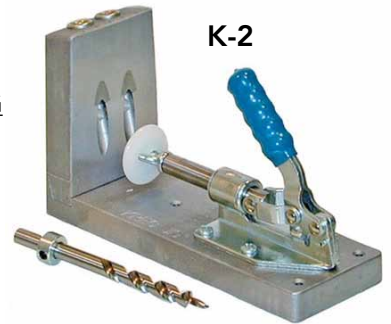

- Hardened steel drill guides on all systems
- Cuts through hardwood, plywood, and particle board with ease; also melamine without splitting
- No set-up required, just place wood in jig and use a portable hand drill
- No cumbersome machine or time-consuming set-ups
- Just clamp and drill to produce a pocket with a pilot hole ready to accept a screw
- Toggle clamp leaves hands free for safe drilling operation
- Instant bonding and fast assembly
- Portable - takes up very little space
- Very user-friendly



KREG K-2 JIG
(Manual two guides)

<u>Code</u>	<u>List/ea.</u>
K-2	\$ 232.75

REPLACEMENT DRILL
(Stop Collar not included)

<u>Code</u>	<u>List/ea</u>
KA BIT	\$ 36.67



FACE CLAMP

<u>Code</u>	<u>List/ea</u>
FC	\$ 36.87